

Warning ● Ask a qualified installer or contractor to install this product. Do not try to install the product by yourself. Improper installation can result in water or refrigerant leakage, electrical shock, fire or explosion.

● Use only those parts and accessories supplied or specified by Daikin. Ask a qualified installer or contractor to install those parts and accessories. Use of unauthorised parts and accessories or improper installation of parts and accessories can result in water or refrigerant leakage, electrical shock, fire or explosion.

● Read the user's manual carefully before using this product. The user's manual provides important safety instructions and warnings. Be sure to follow these instructions and warnings.

If you have any enquiries, please contact your local importer, distributor and/or retailer.

**Cautions on product corrosion**

1. Air conditioners should not be installed in areas where corrosive gases, such as an acidic or alkaline gas, are produced.
2. When installing outdoor units in coastal areas, be sure to contact your local distributor and avoid direct exposure of the units to sea breezes.

**Đại lý phân phối**

**CÔNG TY CỔ PHẦN DAIKIN AIR CONDITIONING (VIETNAM)**

VĂN PHÒNG CHÍNH  
Tầng 12, tòa nhà Nam Á, 201-203 Cách Mạng Tháng 8, P.4, Q.3, TP. Hồ Chí Minh, Tel: (028) 62 504 888

**CHI NHÁNH HÀ NỘI**  
Tầng 12, tòa nhà Ocean Park Tower,  
1 Đào Duy Anh, Q. Đống Đa, Hà Nội  
Tel: (024) 3565 7677

**CHI NHÁNH HẢI PHÒNG**  
Số 7 lô 8A đường Lê Hồng Phong,  
P. Đông Khê, Q. Ngô Quyền, TP. Hải Phòng  
Tel: (0225) 383 2900

**CHI NHÁNH ĐÀ NẴNG**  
Tầng 12, tòa nhà PVcomBank, Lô A2.1, Đường 30/4,  
P. Hòa Cường Bắc, Q. Hải Châu, TP. Đà Nẵng  
Tel: (0236) 362 4250

**CHI NHÁNH CẦN THƠ**  
37-38 Võ Nguyên Giáp, Khu dân cư Phú An,  
P. Phú Thứ, Q. Cái Răng, TP. Cần Thơ  
Tel: (0292) 626 9977

**CHI NHÁNH KHÁNH HÒA**  
1200 Lê Hồng Phong, P. Phước Long,  
TP. Nha Trang  
Tel: (0258) 625 8158



DaikinVietnam www.daikin.com.vn

● Specifications, designs and other content appearing in this brochure are current as of January 2019 but subject to change without notice.



# New Inverters Launched!



**R-32** Super Inverter

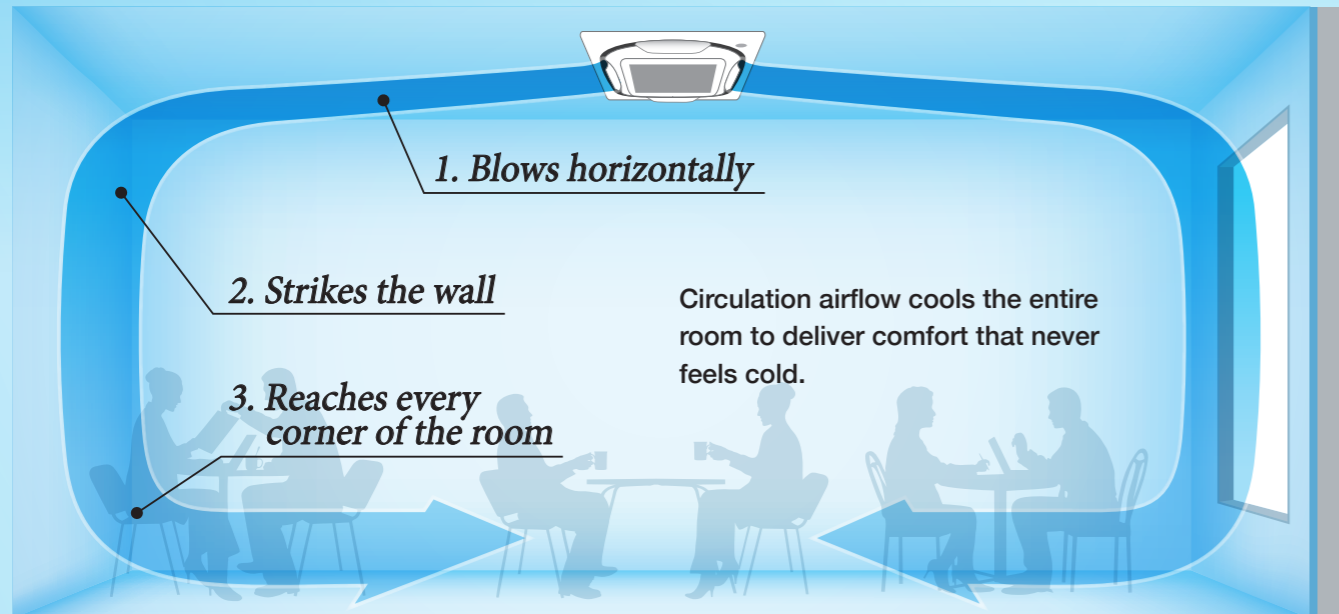

## Energy Saving

Comparison of cooling seasonal power consumption based on average CSPF values

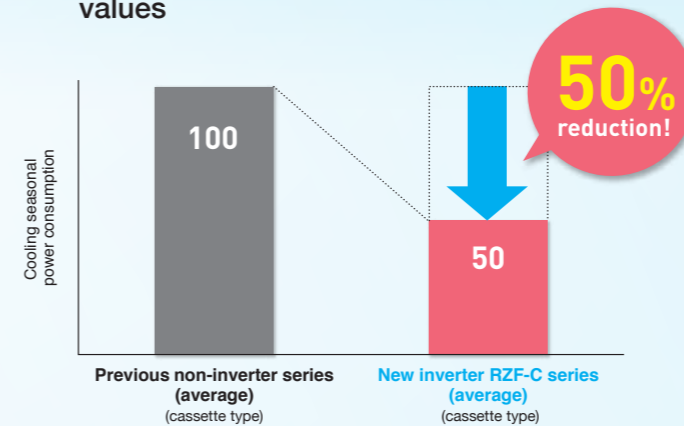

## Compact

New outdoor units save even more space

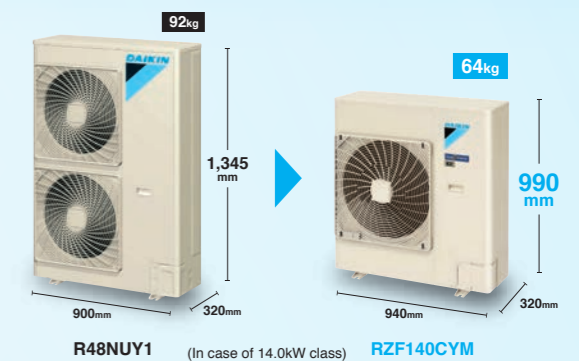

## From R-410A to R-32, Another step towards lower global warming potential.

If you want a new HFC refrigerant with zero ozone depletion potential, which also has a lower global warming potential than R-410A, use R-32. Achieving new levels of energy efficiency while responding to environmental needs, Daikin has redesigned the SkyAir series right from the basic design to use R-32.

100-year global warming potential (GWP) of different refrigerants

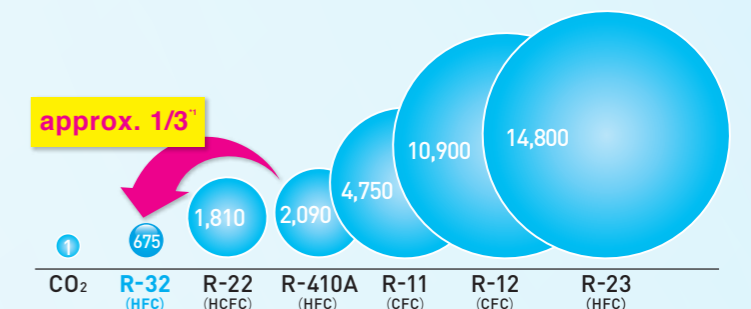

\*1. Source: Values for 100-year global warming potential (GWP) from IPCC Fourth Assessment Report. Comparative 100-year GWP: HFC410A, 2,090; HFC32, 675.



# Circulation Airflow Evenly Distributes Cool and Warm Air\*1

\*1. Applicable when wired remote controller BRC1E63 is used.

New Round Flow Cassette movie in Vietnamese at Daikin official YouTube site.



## Cooling

Airflow until now had areas that were either too cool or not cool enough. 😞

**Problem 1**  
Hot outdoor air entering through windows and walls causes these areas to become hot.

**Problem 2**  
Cool air accumulating directly underneath causes cold air pockets at floor level.

**Problem 3**  
Airflow blowing directly on people causes discomfort for people in the room.

**Problem 4**  
Quick descent of cool air causes insufficient cooling for corners of the room.

**4-Way Flow**

Circulation airflow cools the entire room to deliver comfort that never feels cold. 😊

**During 2-way horizontal flow**

Airflow effectively avoids blowing air directly on people.

Cool air moves down along the walls and to every corner of the room.

Comfort without cold air pockets at floor level.

Cools by airflow blocking out hot air near windows and walls.

**Hot outdoor air**

## Configurations of Circulation Airflow (Cooling)

Operation (at start) → Performs repeatedly → When the set temperature is reached, normal operation (all-round flow) begins.

Cools areas around walls using 2-way horizontal flow

Cools entire room using 4-way swing flow

Cools areas around walls using 2-way horizontal flow

Cools entire room using 4-way swing flow

Note: Results may vary depending on equipment conditions, room size, and distance from indoor unit to walls.

## Heating

Airflow until now (only downward flow) did not warm areas at floor level or near windows and walls. 😞

**Problem 1**  
Outdoor air entering through windows and walls causes areas near windows and walls to be cold.

**Problem 2**  
Warm air does not reach floor level, and areas at floor level remain cold.

**Problem 3**  
Warm air blowing directly on people causes discomfort from air conditioner.

**Problem 4**  
Room is slow to get warm because warm air does not reach to all corners.

**4-Way Flow**

**Cold outdoor air**

Circulation airflow warms the entire room starting from your feet. 😊

**During 2-way horizontal flow**

Airflow effectively avoids blowing air directly on people.

Airflow quickly makes the entire room warm and comfortable.

Warmth reliably reaches feet.

Warms by airflow blocking out cold air near windows and walls.

**Cold outdoor air**

## Configurations of Circulation Airflow (Heating)

Operation (at start) → Performs repeatedly → When the set temperature is reached, normal operation (all-round flow) begins.

Warms areas around walls using 2-way horizontal flow

Warms the middle of the room using 4-way down flow

Warms areas around walls using 2-way horizontal flow

Warms the middle of the room using 4-way down flow



# Circulation Airflow Evenly Distributes Cool and Warm Air\*1

\*1. Applicable when wired remote controller BRC1E63 is used.

New Round Flow Cassette available in Vietnamese at Daikin official YouTube site.



## Comfort to the Entire Room with Even Temperatures and No Cold Air Pockets at Floor Level

### Cooling

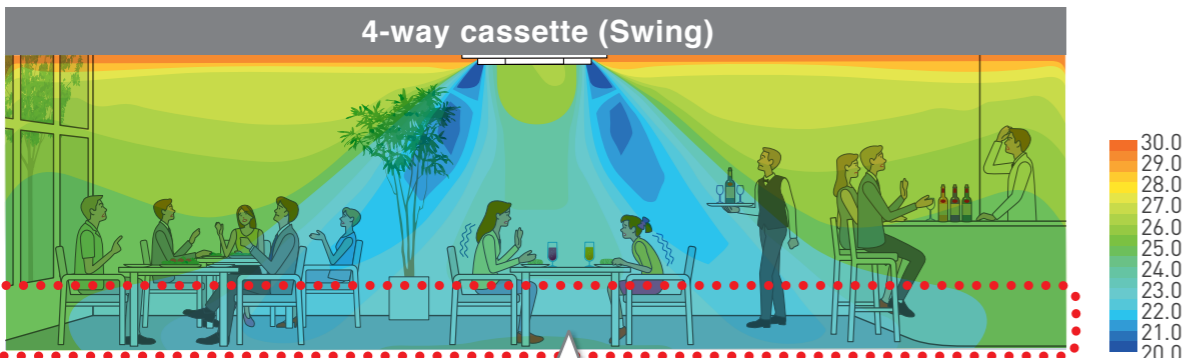

Areas at floor level are cold while areas around walls are hot.

**Comparison Conditions**

- Room size: Width 7.5m x depth 7.5m x height 2.6m
- Indoor unit capacity: 71 class
- Outdoor air temperature: 35°C
- Airflow rate and air direction: high / swing

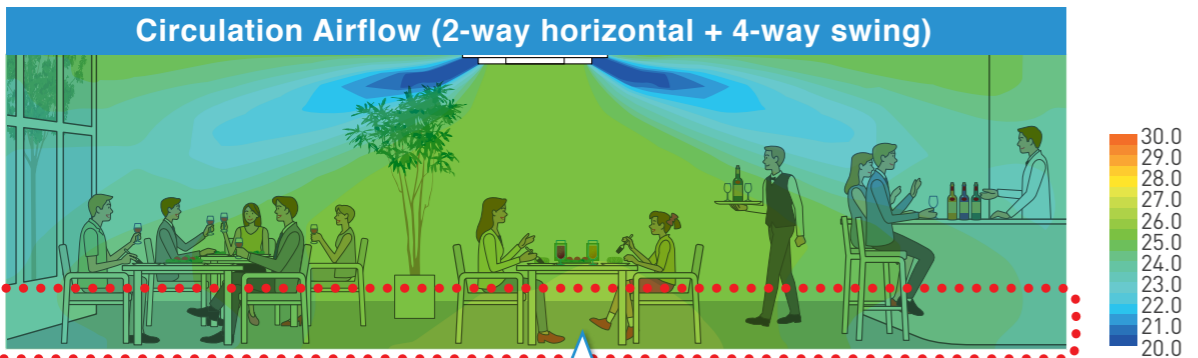

Full comfort is provided with no cold feet.

Approx. 5% energy savings\*2 by reducing uneven temperatures

\*2. Calculated under the following comparison conditions: When the average temperature at a height of 0.6m above the floor reaches set temperature. (26°C)

## Comfort to the Entire Room with Even Temperatures and Warmth Reaches Feet

### Heating

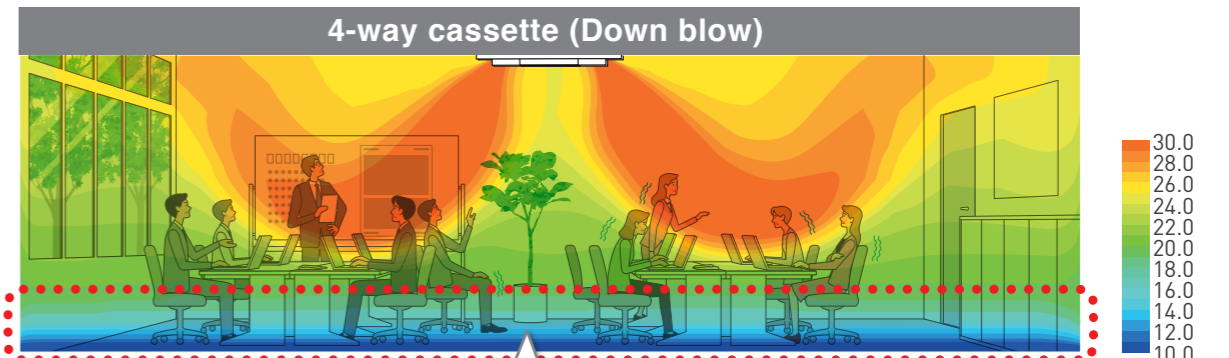

Areas around walls and feet are cold.

**Comparison Conditions**

- Room size: Width 7.5m x depth 7.5m x height 2.6m
- Outdoor air temperature: 5°C
- Indoor unit capacity: 71 class
- Airflow rate and air direction: high / Down blow

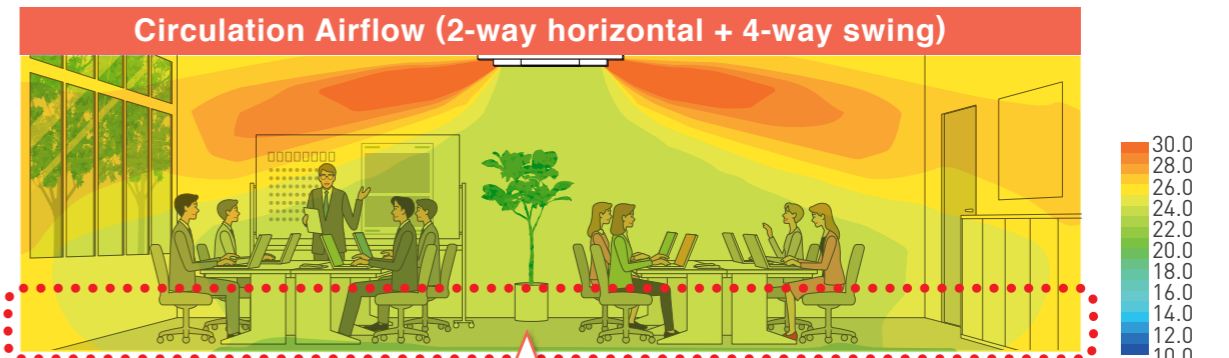

Areas around walls and feet are warm.

Approx. 15% energy savings\*3 by reducing uneven temperatures

\*3. Calculated under the following comparison conditions: When the average temperature at a height of 0.6m above the floor reaches set temperature. (22°C)

## Three Technologies That Achieved Circulation Airflow

### 1 Use of new wide flaps (Straight)

With new, larger flaps, a straighter trajectory for airflow was achieved.



### 2 Optimizing airflow angle (Horizontally)

The airflow angle was made more horizontal.

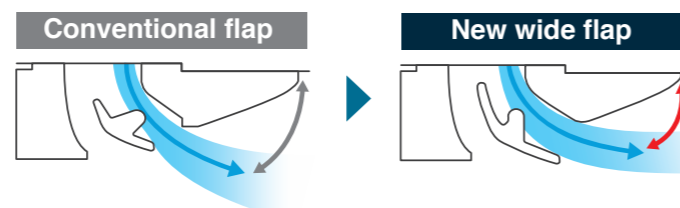

### 3 Increased velocity in 2-way flow (Strongly)

Velocity increased by making 2-way flow. Powerful airflow was realized.

\*Other 2 outlets are controlled by changing the flap direction (angle) to suppress airflow volume.

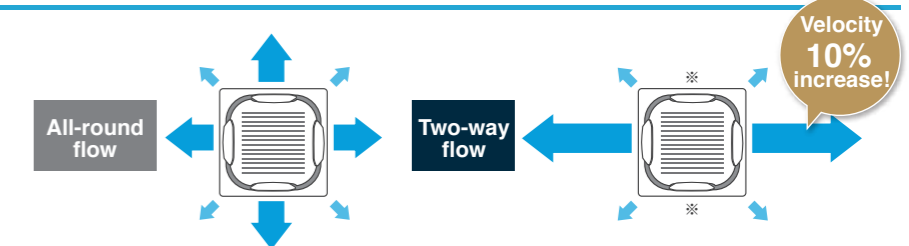

## Things to remember when using circulation airflow

### Main points for use

- Effectiveness may differ according to room conditions, room size, and distance to walls.
- Airflow operation differs when using the designer panel. (Operation repeatedly switches from 3-way horizontal flow to 4-way downward flow [swing] to 2-way horizontal flow to 4-way downward flow [swing].)
- Circulation airflow functions during connection with wired remote controller. (BRC1E63). However, use is not possible for the following conditions:
  - When a sealing material of air discharge outlet and branch ducts are used;
  - When individual airflow setting is selected;
  - When using group control other than round flow.

### Installation conditions

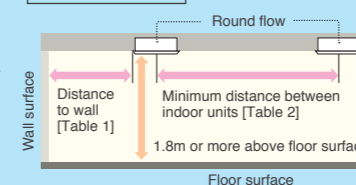

[Table 1]

Distance to wall from indoor unit

Indoor unit capacity	FCF50-71	FCF100-140
Maximum distance	1.5-5m	1.5-7m

[Table 2]

Minimum distance between indoor units

Indoor unit capacity	FCF50-71	FCF100-140
Minimum distance	5m or more	7m or more

# NEW Individual Airflow Direction Control\*1

\*1. Applicable when wired remote controller BRC1E63 is used.

## Comfortable air conditioning for all room layouts and conditions

Airflow direction can be individually adjusted for each air discharge outlet to deliver optimal air distribution.

Easy setting is possible with a wired remote controller.

NEW BRC1E63

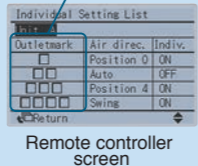

There are identification marks near the air outlets.

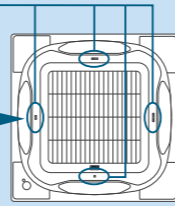

Position 0  
(Fixed airflow to highest position)

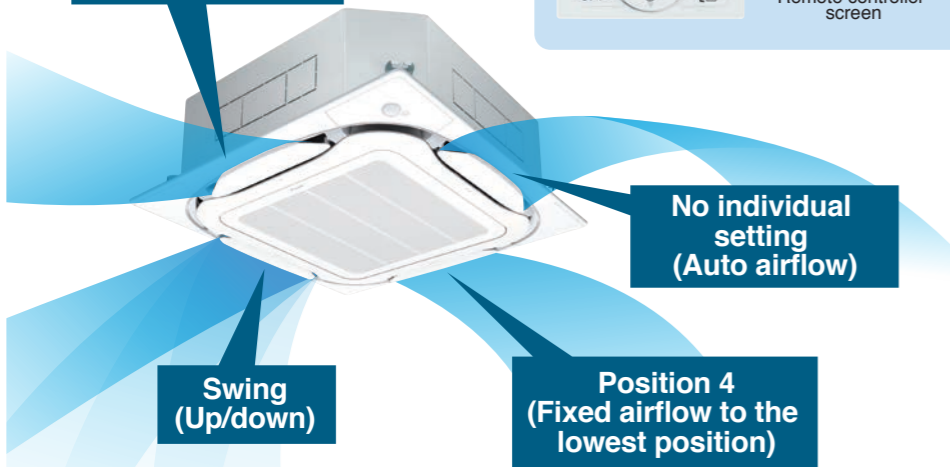

No individual setting  
(Auto airflow)

### Individual airflow settings

- No individual setting (Auto airflow)
- Position 0 (Highest point)
- Position 1
- Position 2
- Position 3
- Position 4 (Lowest point)
- Swing

Individual settings are possible as stated above.

## When individual airflow is selected, airflow direction can be adjusted to room layout.

### For shops and restaurant

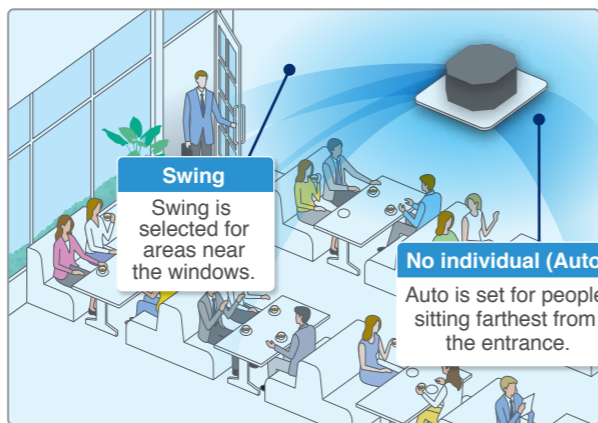
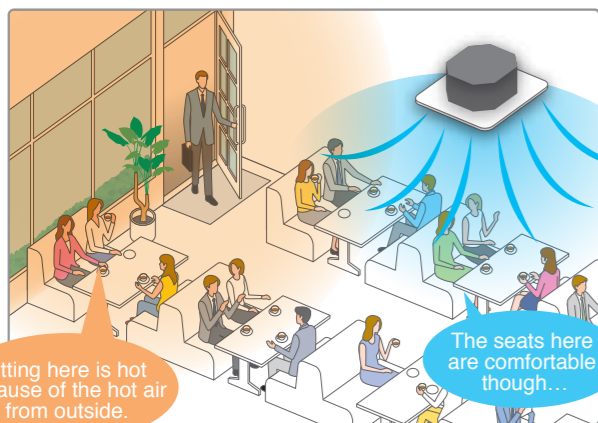

### For offices

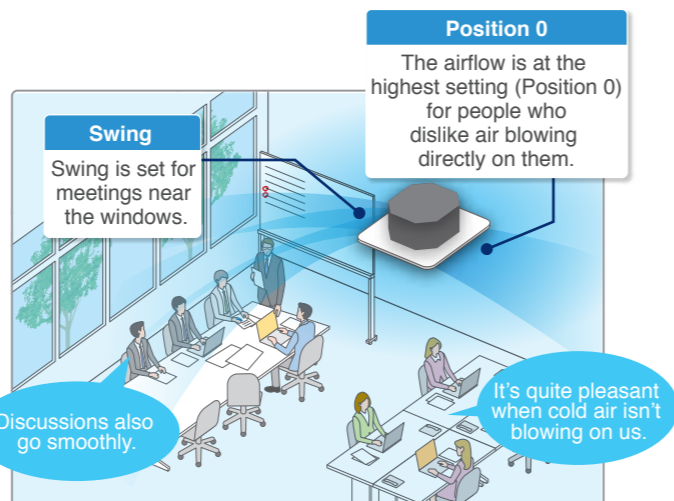
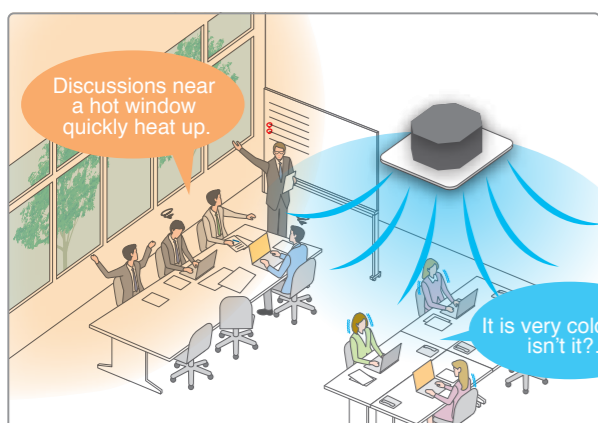

# NEW Daikin Sensing Technology\*1,2

\*1. Applicable when wired remote controller BRC1E63 is used.  
\*2. Applicable when sensing panel (BYCQ125EEF/EEK) is installed.

New Round Flow Cassette movie in Vietnamese at Daikin official YouTube site.



## Dual Sensors\*2

Dual sensors and individual airflow direction control automatically provide optimal control of airflow.

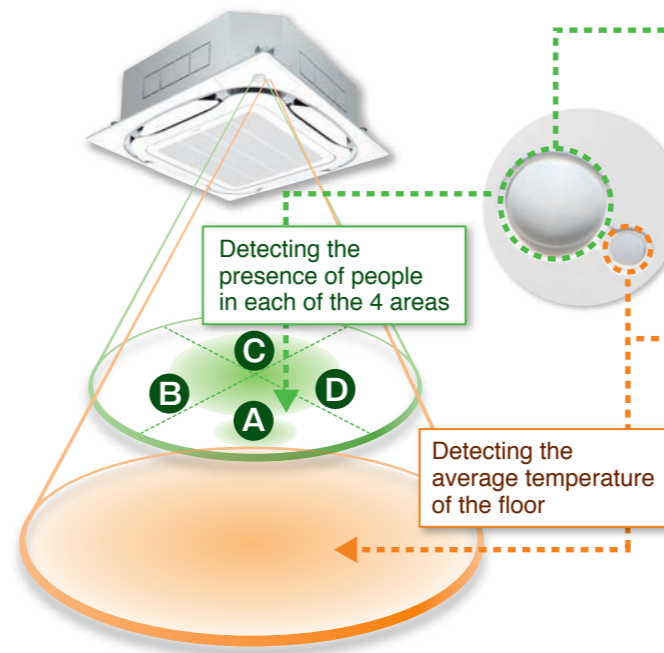

### Infrared presence sensor

The sensor detects the presence of people in each of the 4 areas.

Ceiling height	2.7m	3.5m	4.0m
Detection range (diameter) <sup>*3</sup>	approx. 8.5m	approx. 11.5m	approx. 13.5m

\*3. The infrared presence sensor detects 80cm above the floor.

### Infrared floor sensor

The sensor detects the floor temperature and automatically adjusts operation of the indoor unit to reduce the temperature difference between the ceiling and the floor.

Ceiling height	2.7m	3.5m	4.0m
Detection range (diameter) <sup>*4</sup>	approx. 11m	approx. 14m	approx. 16m

\*4. The infrared floor sensor detects at the floor surface.

## Auto Airflow Functions\*5

\*5. Airflow direction should be set to "Auto".

### Direct Airflow (default: OFF) Cooling Dry

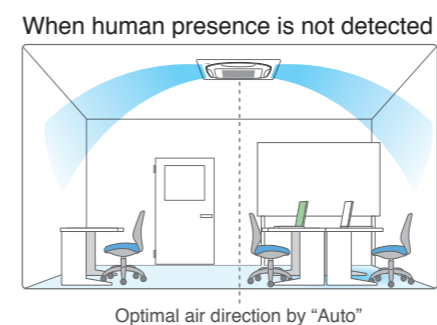

- With "Auto" airflow direction mode, flaps are controlled to deliver optimal airflow when the room is unoccupied.

### When human presence is detected

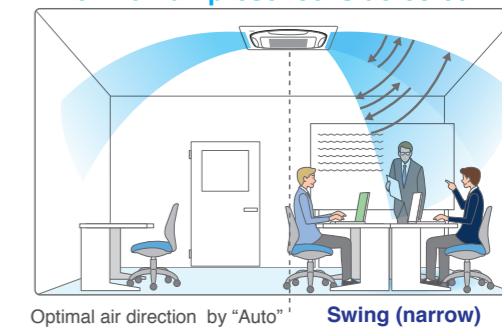

- When presence is detected, air direction is set to "Swing (narrow)" to deliver cool air to users.

### Draft prevention (default: OFF) Heating

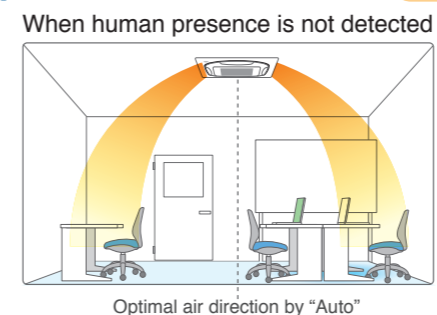

- With "Auto" airflow direction mode, flaps are controlled to deliver optimal airflow when the room is unoccupied.

### When human presence is detected

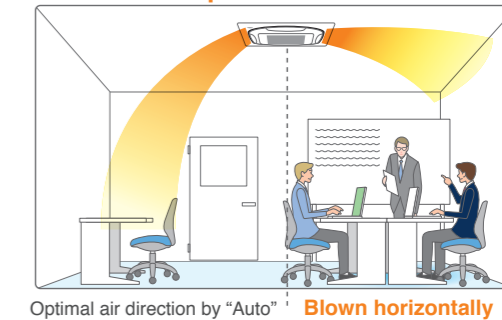

- When presence is detected, drafts are prevented by making the flap horizontal.

# Daikin provides your on-demand inverters with a variety of indoor units



*Ceiling mounted cassette type  
(Standard panel with Sensing)*



*Ceiling mounted cassette type  
(Standard panel)*



*Ceiling mounted slim duct type*



*Ceiling mounted cassette type  
(Designer panel)*



*Compact multi flow ceiling mounted cassette type*

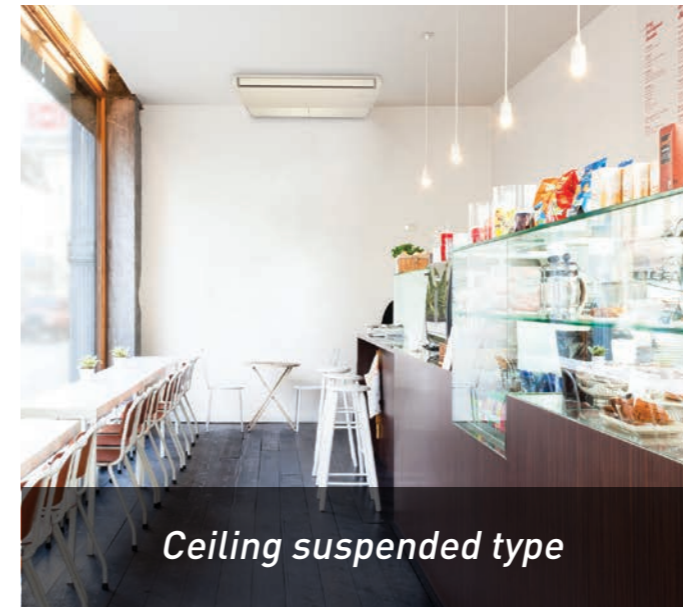

*Ceiling suspended type*

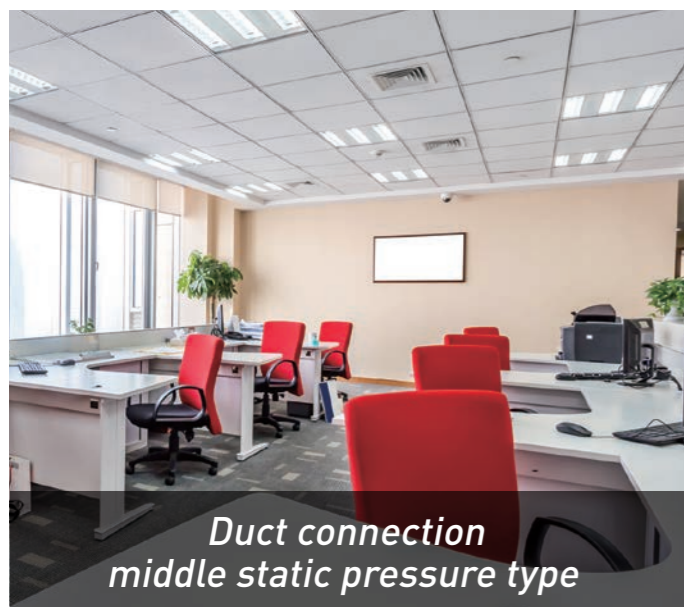

*Duct connection middle static pressure type*



*Duct connection middle static pressure type*



*Floor standing type*

## INDEX

<b>New Round Flow Cassette</b>	
Circulation Airflow	P.3-6
Individual Airflow Direction Control	P.7
Sensing Technology	P.8
<b>Installation Image</b>	P.9-10
<b>Lineup</b>	P.11-12
<b>Daikin SkyAir Series</b>	
Energy Saving	P.13
Compact & Lightweight	P.14
Quick Cooling	P.15
Benefits of Inverters	P.16
Durability	P.17
Convenient Functions	P.18
Reuse of Existing Piping	P.19
Design Flexibility	P.20
Smart Airflow Control	P.21
Special Situations	P.21
<b>Indoor Unit</b>	P.22
Ceiling Mounted Cassette type <Round Flow>	P.23-32
Compact Multi Flow Ceiling Mounted Cassette type	P.33-34
Ceiling Mounted Slim Duct type	P.35-36
Duct Connection Middle Static Pressure type	P.37-38
Ceiling Suspended type	P.39-40
Floor standing type	P.41-42
<b>Outdoor Unit</b>	P.43-44
<b>Remote Controller</b>	P.45-47
<b>Functions</b>	P.49-54
<b>Specifications</b>	P.55-61
<b>Options</b>	P.62-64
<b>Dimensions</b>	P.65-77
<b>Installation Service Space for Outdoor Unit</b>	P.78

















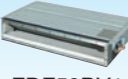
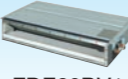





# Product Lineup



















Super Inverter

R-32





SkyAir





Cooling only

Series	50	60	71
<b>CEILING MOUNTED CASSETTE TYPE</b> <Round Flow> 			
	Indoor unit FCF50CVM	Indoor unit FCF60CVM	Indoor unit FCF71CVM
	Outdoor unit RZF50CV2V	Outdoor unit RZF60CV2V	Outdoor unit RZF71CV2V   RZF71CYM
<b>COMPACT MULTI FLOW CEILING MOUNTED CASSETTE TYPE</b>			
	Indoor unit FFF50BV1	Indoor unit FFF60BV1	
	Outdoor unit RZF50CV2V	Outdoor unit RZF60CV2V	
<b>CEILING MOUNTED SLIM DUCT TYPE</b>			
	Indoor unit FDF50BV1	Indoor unit FDF60BV1	
	Outdoor unit RZF50CV2V	Outdoor unit RZF60CV2V	
<b>DUCT CONNECTION MIDDLE STATIC PRESSURE TYPE</b>			
	Indoor unit FBA50BVMA	Indoor unit FBA60BVMA	Indoor unit FBA71BVMA
	Outdoor unit RZF50CV2V	Outdoor unit RZF60CV2V	Outdoor unit RZF71CV2V   RZF71CYM
<b>CEILING SUSPENDED TYPE</b>			
	Indoor unit FHA50BVMV	Indoor unit FHA60BVMV	Indoor unit FHA71BVMV
	Outdoor unit RZF50CV2V	Outdoor unit RZF60CV2V	Outdoor unit RZF71CV2V   RZF71CYM
<b>FLOOR STANDING TYPE</b>	 	 	 
	Indoor unit FVA50AMVM	Indoor unit FVA60AMVM	Indoor unit FVA71AMVM
	Outdoor unit RZF50CV2V	Outdoor unit RZF60CV2V	Outdoor unit RZF71CV2V   RZF71CYM
<b>OUTDOOR UNIT</b>			 
	Outdoor unit RZF50CV2V	Outdoor unit RZF60CV2V	Outdoor unit RZF71CV2V   RZF71CYM
		Power supply 1 phase, 220V, 50Hz	Power supply 3 phase, 380-415V, 50Hz

100	125	140
		
Indoor unit FCF100CVM	Indoor unit FCF125CVM	Indoor unit FCF140CVM
Outdoor unit RZF100CVM   RZF100CYM	Outdoor unit RZF125CVM   RZF125CYM	Outdoor unit RZF140CVM   RZF140CYM
		
Indoor unit FBA100BVMA	Indoor unit FBA125BVMA	Indoor unit FBA140BVMA
Outdoor unit RZF100CVM   RZF100CYM	Outdoor unit RZF125CVM   RZF125CYM	Outdoor unit RZF140CVM   RZF140CYM
		
Indoor unit FHA100BVMV	Indoor unit FHA125BVMA	Indoor unit FHA140BVMA
Outdoor unit RZF100CVM   RZF100CYM	Outdoor unit RZF125CVM   RZF125CYM	Outdoor unit RZF140CVM   RZF140CYM
 	 	 
Indoor unit FVA100AMVM	Indoor unit FVA125AMVM	Indoor unit FVA140AMVM
Outdoor unit RZF100CVM   RZF100CYM	Outdoor unit RZF125CVM   RZF125CYM	Outdoor unit RZF140CVM   RZF140CYM
		
Outdoor unit RZF100CVM   RZF100CYM	Outdoor unit RZF125CVM   RZF125CYM	Outdoor unit RZF140CVM   RZF140CYM
Power supply 1 phase, 220-240V, 50Hz	Power supply 3 phase, 380-415V, 50Hz	Power supply 1 phase, 220-240V, 50Hz 3 phase, 380-415V, 50Hz

Heat Pump

Series	50	60	71
<b>CEILING MOUNTED CASSETTE TYPE</b> <Round Flow>			
	Indoor unit		Indoor unit FCF71CVM
			Outdoor unit RZA71BV2V
<b>DUCT CONNECTION MIDDLE STATIC PRESSURE TYPE</b>			
	Indoor unit		Indoor unit FBA71BVMA
			Outdoor unit RZA71BV2V
<b>CEILING SUSPENDED TYPE</b>			
	Indoor unit		Indoor unit FHA71BVMV
			Outdoor unit RZA71BV2V
<b>OUTDOOR UNIT</b>			
	Outdoor unit		Outdoor unit RZA71BV2V
			Power supply 1 phase, 220V, 50Hz

100	125	140
		
Indoor unit FCF100CVM		
Outdoor unit RZA100BV2V		
		
Indoor unit FBA100BVMA		
Outdoor unit RZA100BV2V		
		
Indoor unit FHA100BVMV		
Outdoor unit RZA100BV2V		
		
Outdoor unit RZA100BV2V		
Power supply 1 phase, 220V, 50Hz		

# New Inverters launched

# SkyAir

Super Inverter

R-32

Cooling only

Heat pump

## Energy Saving

### Throughout the cooling season, Daikin's new inverter models reduce energy consumption

Compared with previous non-inverter series, the new RZF-C series uses about 50% less power consumption for quick and effective cooling that reduces electricity bills.

Comparison of cooling seasonal power consumption based on average CSPF values

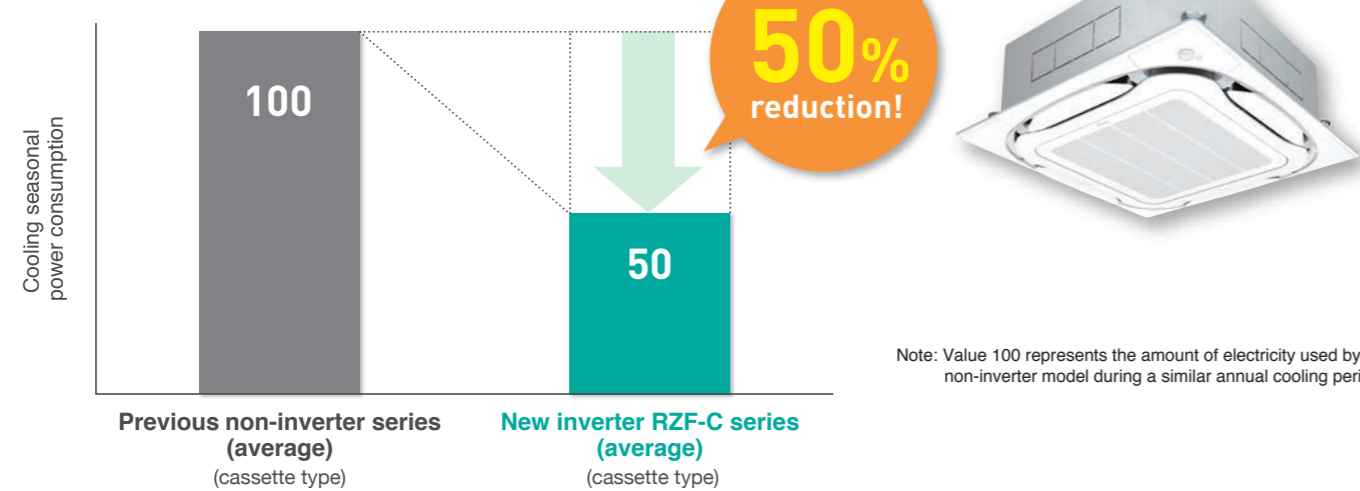

CSPF values by capacity for cassette models

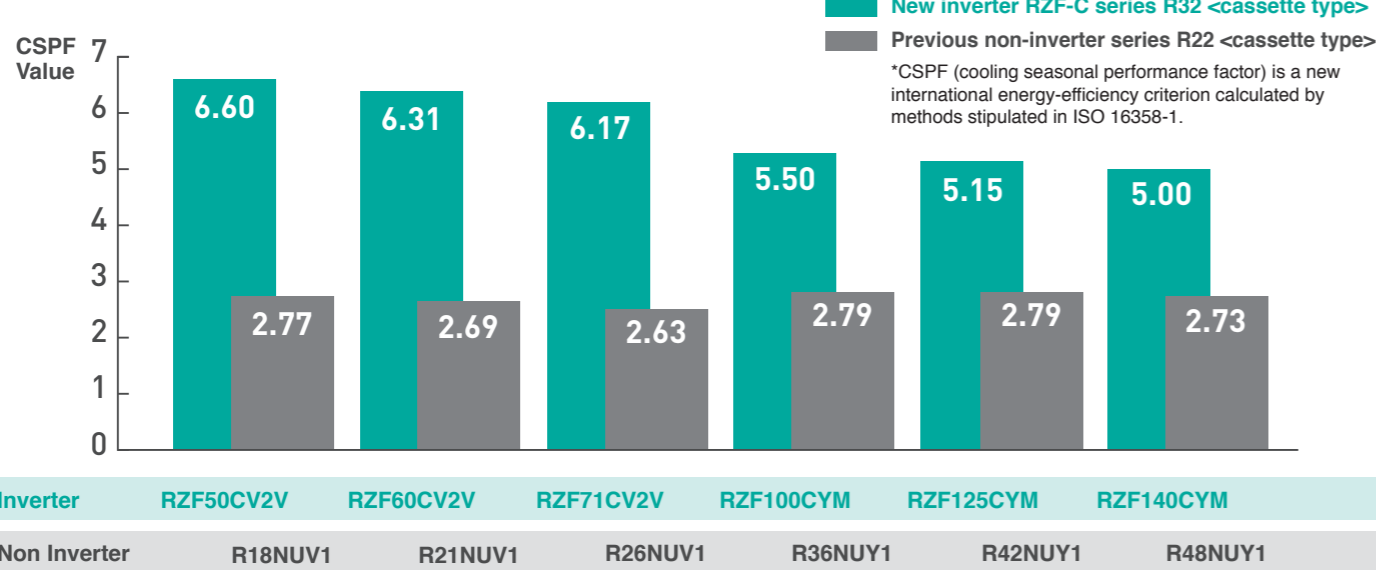

### What is CSPF?

CSPF is the value for the annual total cooling load divided by the annual total power consumption at outdoor air conditions specified by ISO standard.

## Compact & Lightweight

### New outdoor units save even more space

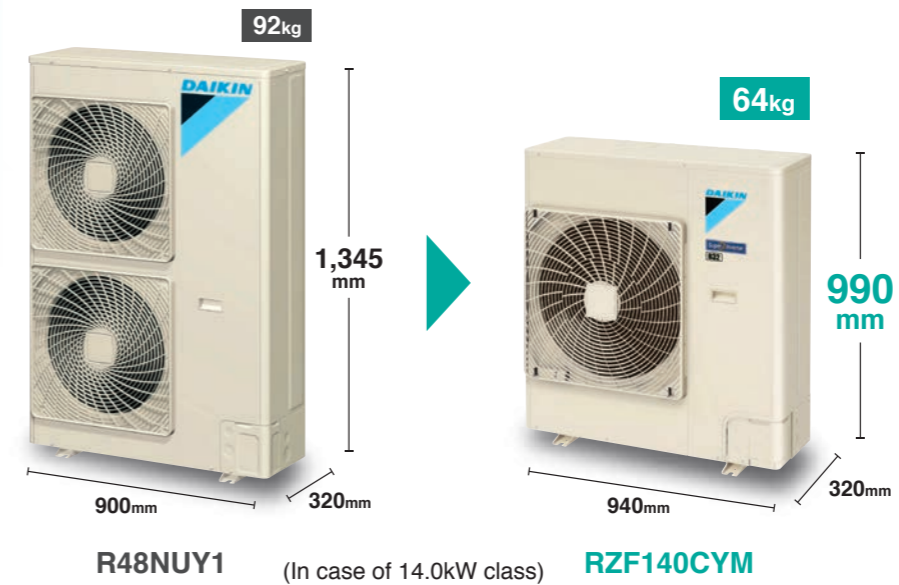

More compact, much higher CSPF!

23% reduction in volume  
0.39m<sup>3</sup> → 0.30m<sup>3</sup>

30% reduction in weight  
92kg → 64kg

### Comparison with the previous mainstream non-inverter series

Outdoor units are much more compact and lighter weight. They enable easy installation in places with limited space.

	7.6 kW R26NUV1 / NUY1	10.6 kW R36NUV1 / NUY1	12.3 kW R42NUY1	14.1 kW R48NUY1
Previous non-inverter R-NU series	70kg 900mm x 770mm	79kg 900mm x 1,170mm	87kg 900mm x 1,170mm	92kg 900mm x 1,345mm
	↓			
	7.1 kW RZF71CV2V	10.0 kW RZF71CYM	12.5 kW RZF100CVM/CYM	14.0 kW RZF140CVM/CYM
New inverter RZF-C series	41kg 845mm x 595mm	48kg 930mm x 695mm	48kg 930mm x 695mm	64kg 940mm x 990mm
Reduced by	29kg	22kg	31kg	28kg

Unit weight is greatly reduced.



## Quick Cooling

### Faster cooling and dehumidification

New inverter control technology brings quick comfort.

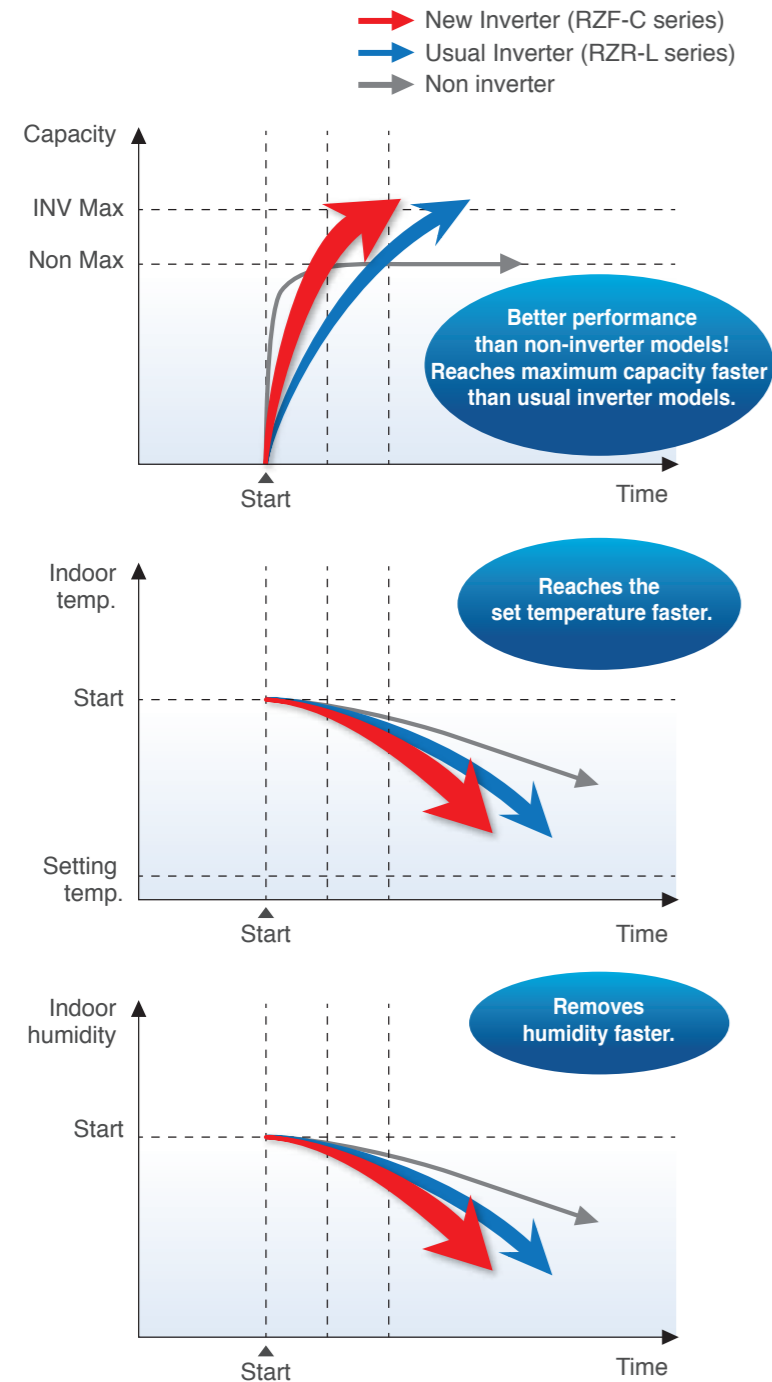

### Quick cooling start function

Quickly and easily make space comfortable before the arrival of office workers or shop customers. As well as quick cooling at maximum capacity, new inverter control rapidly removes indoor humidity. More than simple temperature reduction, this twin reduction provides greater comfort (within a maximum of 30 minutes).



● BRC1E63 wired remote controller is used for 'Quick cooling start'.



## Benefits of Inverters

### Why is inverter technology economical?

**Inverter system consumes less electricity, and soon recovers the difference in initial cost. This results in lower total cost.**

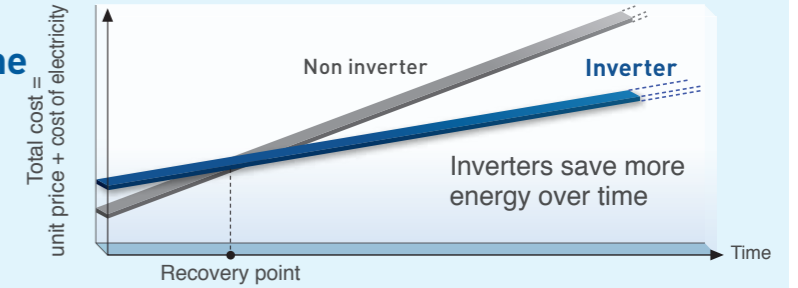

**Inverter air conditioner can adjust its cooling capacity according to the cooling load. This results in less power consumption.**

In response to fluctuating cooling load, Non inverter air conditioners repeatedly perform ON (full-power)/OFF (zero-power) operation. Inverter air conditioners, however, operate at optimal cooling capacity according to the cooling load. Since inverter air conditioners provide required minimum cooling capacity with minimum electrical power, total power consumption can be reduced during cooling period.

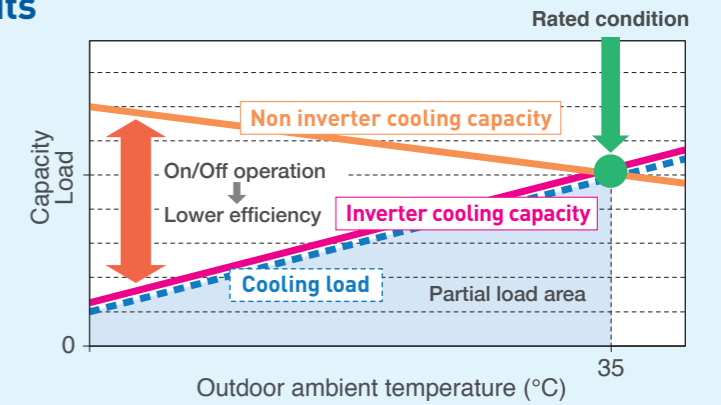

**Inverters operate without repeated ON/OFF operation.**

**Inverter Highway driving**

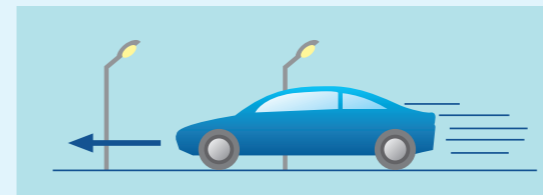

Continuous driving without stopping and starting is more fuel efficient.

**Non inverter City driving**

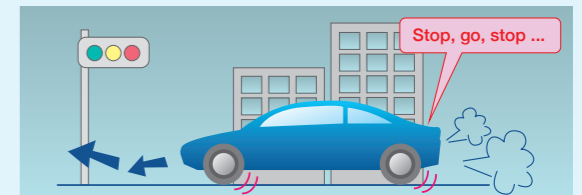

Constantly stopping and starting consumes energy and is less fuel efficient.

### Why is inverter technology more comfortable?

**When temperature does not fluctuate much, the set temperature is maintained.**

Inverter control responds to load changes and causes minor temperature adjustments. Non-inverter control frequently turns ON and OFF in response to load fluctuations or load mismatch and causes large temperature swings.

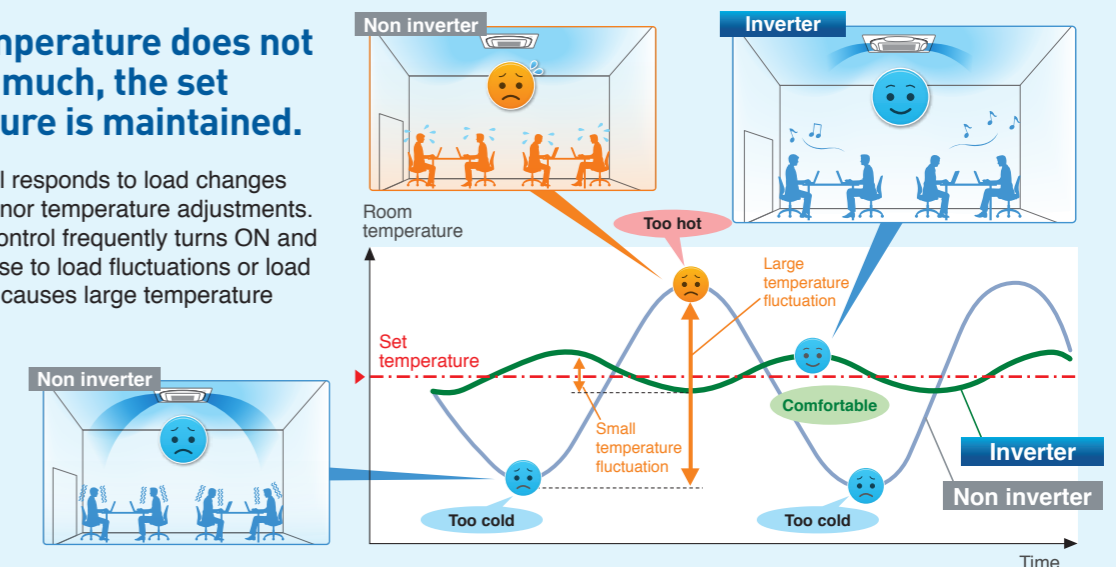

## Durability

### Overvoltage PCB (Outdoor unit option)

RZF series only

See page 64

Unstable power supply is a common problem in many regions. It can cause overvoltage which can significantly damage electronic devices. To prevent voltage fluctuations, it is usually necessary to attach a stabiliser when installing an air conditioner. The RZF-C series is equipped with a highly-durable electronic circuit. This circuit eliminates the need for a stabiliser and offer additional protection for devices in the outdoor unit, such as its fan motor and compressor.

### Automatic protection against low voltage

In AM and PM peak electricity consumption periods, supply may fluctuate. Built-in low-voltage protection will automatically cut operations. When normal voltage is restored, operation will resume as before.

### Outdoor unit installation is possible even with limited space

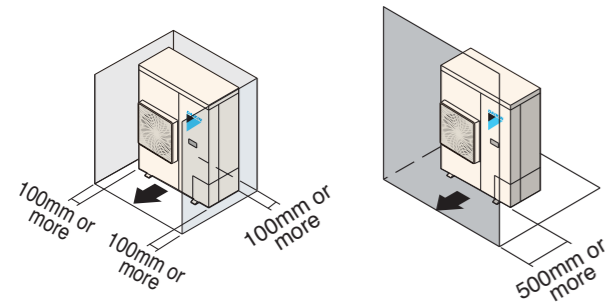

### Microchannel heat exchanger (RZF series only)

Microchannel technology utilises superior heat transfer benefits of aluminium to create a more efficient air conditioner. With a new resistance corrosion aluminium alloy, the Daikin microchannel heat exchanger becomes highly durable. A salt spray test has been conducted to demonstrate the corrosion-resistant capability of our products in corrosive environments for a certain period of time.

#### Test of durability

- Testing organization: MTEC Thailand
- Testing standard: ASTM B117
- Result

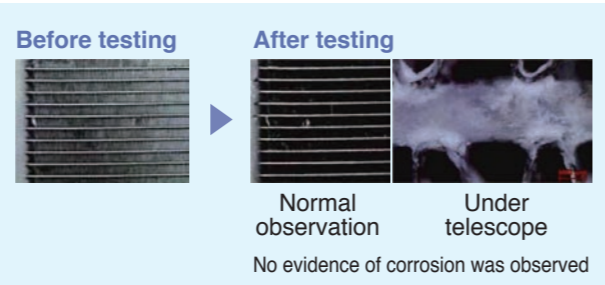

After undergoing an intensive test, the Daikin microchannel heat exchanger is able to maintain its shape without corrosion, which strongly confirms its durability in a highly corrosive environment.

### Coated printed circuit boards (outdoor unit)

Coated circuit boards prevent problems caused by humidity and airborne dust. It also protects against salt contained in sea breezes. Both sides of the PCB in outdoor units are coated.

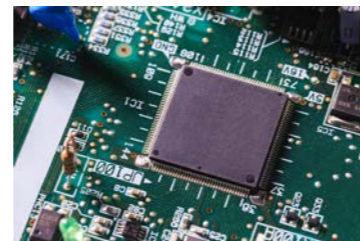

### Self-diagnosis functions enable prompt maintenance response

An error message appears on the LCD of the remote controller and an LED lights up on the unit. When the BRC1E63 is installed, the error code appears showing contact information and model name. Contact your Daikin dealer and provide the error code and model name.

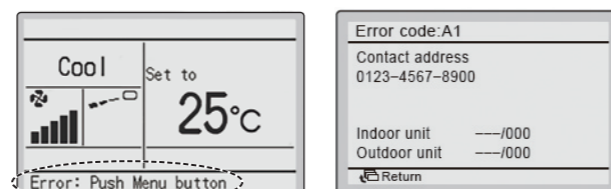

## Convenient Functions

### Navigation remote controller BRC1E63 includes various convenient functions

Automatic return to temperature preset by owner.

#### Setpoint auto reset

- Even if the set temperature is changed, the new set temperature returns to the previous preset value after a preset duration of time.
- Period selectable from 30, 60, 90, or 120 minutes.

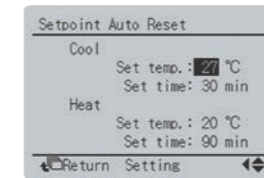

Owner can preset upper and lower temperatures.

#### Setpoint range set

- Saves energy by limiting the min. and max. set temperature.
- Avoids excessive heating or cooling.
- This function is convenient if the remote controller is installed where anyone can change the settings.

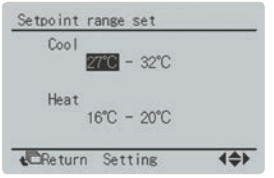

### Restaurant example

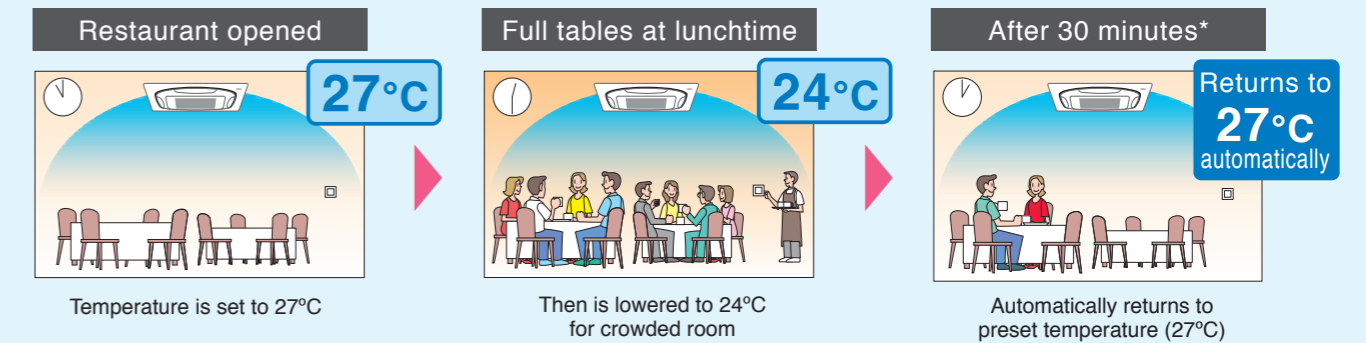

\*Preset-return time can be set at 30, 60, 90, or 120 min

### Demand control function

By setting limits that restrict power consumption, you can cut electricity bills.

- Power consumption is given first priority, and limits maximum power consumption of unit.
- Maximum power consumption can be set at 40, 60, 70, 80, or 100%.

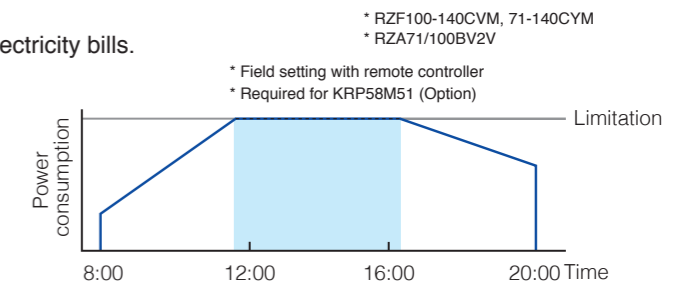

\* RZF100-140CVM, 71-140CYM  
\* RZA71/100BV2V

\* Field setting with remote controller  
\* Required for KRP58M51 (Option)

### Night quiet operation mode

Consideration is given for people living nearby. Outdoor unit operating sound can be reduced.

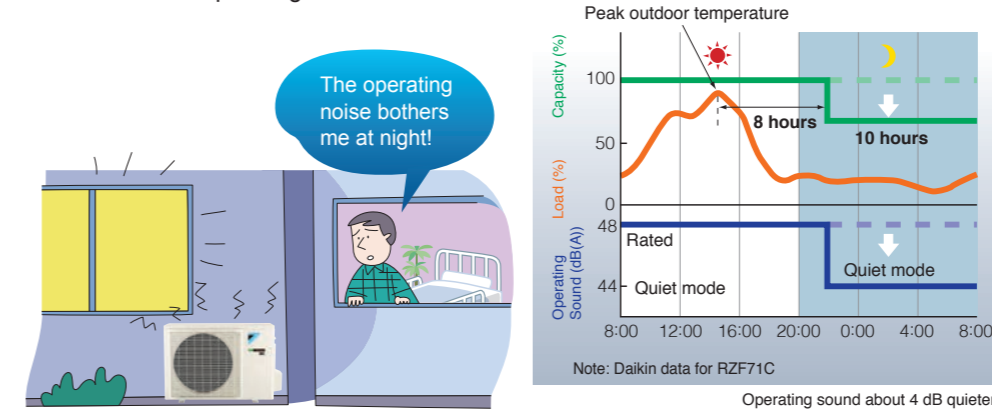

\*Field setting with remote controller



## Reuse of Existing Piping

RZF series only

### Benefit 1

#### Simplified installation reduces replacement time and cost

When considering air conditioner replacement, do the following things concern you?

- The length of time the business will be closed
- Effect on sales during replacement work
- High costs and long work period due to scaffolding needed for pipe replacement

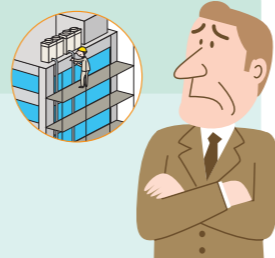

These problems are solved by Daikin!

Where feasible, we reduce work costs and time by reusing existing pipes\*.

\*Strict conditions apply, please check the table on page 43 for acceptable pipe sizing (if pipes are to be reused).

### Benefit 2

#### You can increase cooling capacity and achieve higher energy efficiency

Upgrade to an air conditioner with the latest technology for greater comfort and energy efficiency.

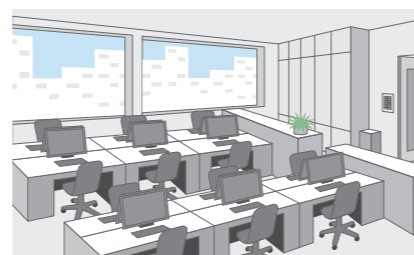
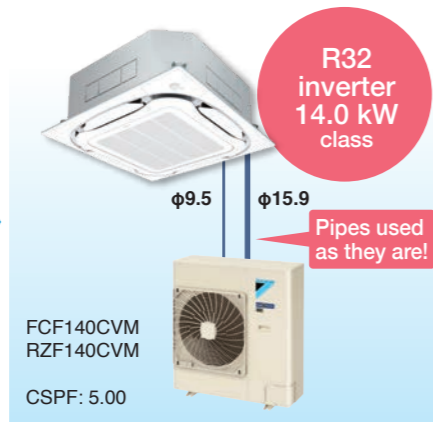
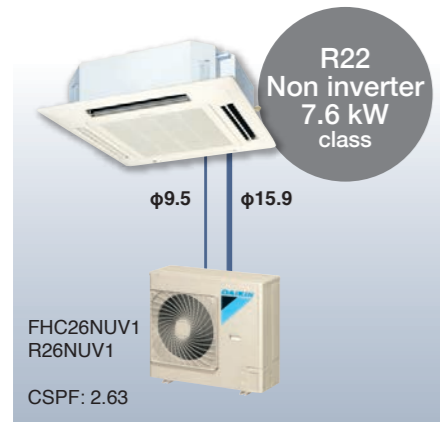

As a result, the greater capacity units ensure better performance to cope with the increasing amount of heat generated by office equipment and occupants.

### Technology

Advanced technology, including the use of corrosion resistant electronic expansion valves, acid neutralisers and improved compressor reliability, enables the re-use of existing piping\* without the need of pipe flushing for a simplified replacement process.

<h4>Stronger refrigerating machine oil</h4> <p>An acid neutraliser agent is added to disable acids (chlorine ions), which cause corrosion.</p>	<h4>Highly corrosion resistant electronic expansion valve</h4>	<h4>Highly reliable compressor</h4> <p>Compressor durability is improved by installing a filter or accumulator to collect solid foreign substances.</p>
--	--	---

\*Strict conditions apply, please check the table on page 43 for acceptable pipe sizing (if pipes are to be reused).

## Design Flexibility

#### Possible to forced OFF and ON/OFF operation using external command

\*Field setting with remote controller  
\*Except for FFF and FDF series

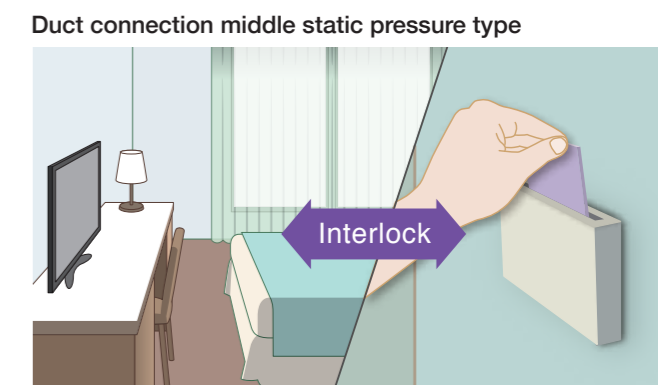
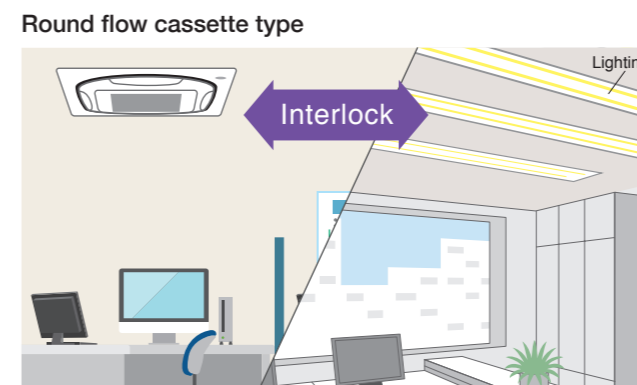

#### External Equipment Interlock (FCF-C series only)

Power conservation is possible through interlock\* of external equipment, such as lighting, with the infrared presence sensor.

\*Optional adaptor for wiring: KRP1C11A is necessary.

Human presence is detected by the built-in infrared presence sensor in the sensing panel, and the presence detection signal can be output and interlocked with external equipment such as ventilation and lighting equipment.

**Sensor interlock mode**  
The presence detection signal of the infrared presence sensor can turn only external equipment ON/OFF without interlocking with air conditioner operation/stop (ON/OFF).

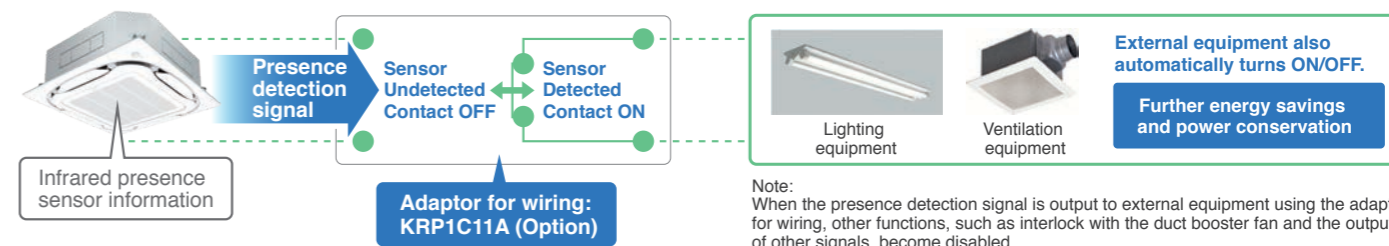

Note:  
When the presence detection signal is output to external equipment using the adaptor for wiring, other functions, such as interlock with the duct booster fan and the output of other signals, become disabled.

#### Indoor units (FCF, FBA, FHA, and FVA series) comply with DIII-Net standards

\*FFF series requires optional adaptor to connect DIII-Net.  
FDF series cannot connect DIII-Net because it cannot use optional adaptor.

#### Previous indoor unit

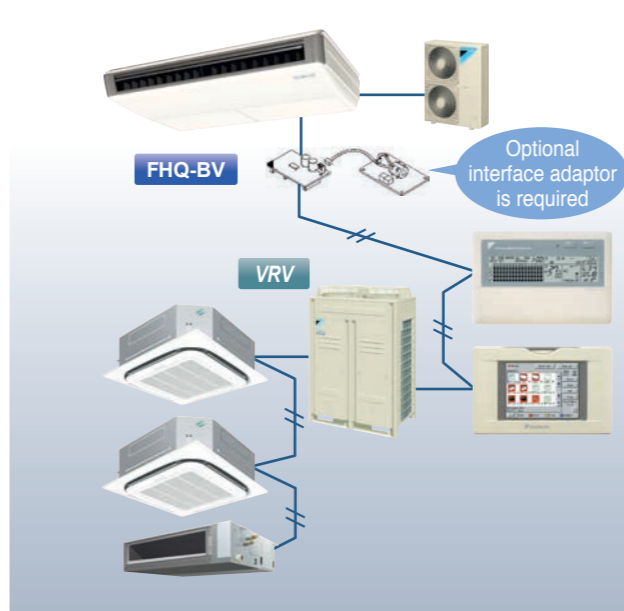

#### New indoor unit

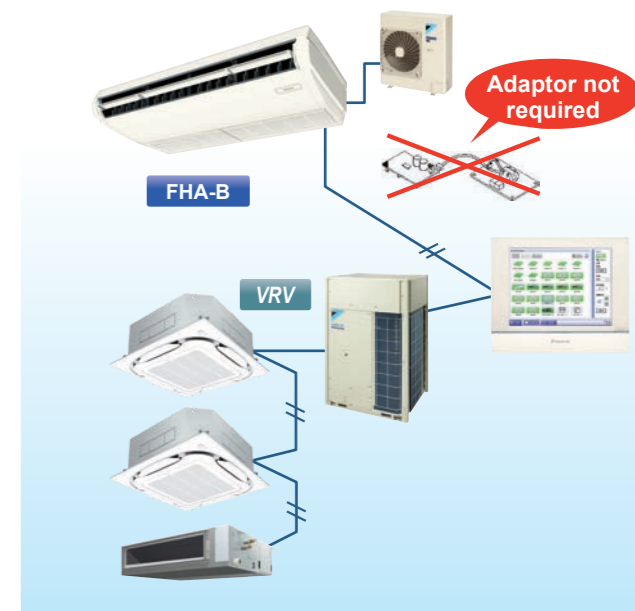

Easy connection to DIII-NET and long piping length makes this solution suitable for projects including VRV and SkyAir.

## Smart Airflow Control

### Indoor units can provide 5-step and 3-step fine control of air volume

5-step: FCF and FHA series  
3-step: FBA and FVA series

### Comfort ensured by 'Auto' airflow rate that matches load level

\*Except for FFF and FDF series

Convenient energy-efficiency for stores with peak and quiet periods.

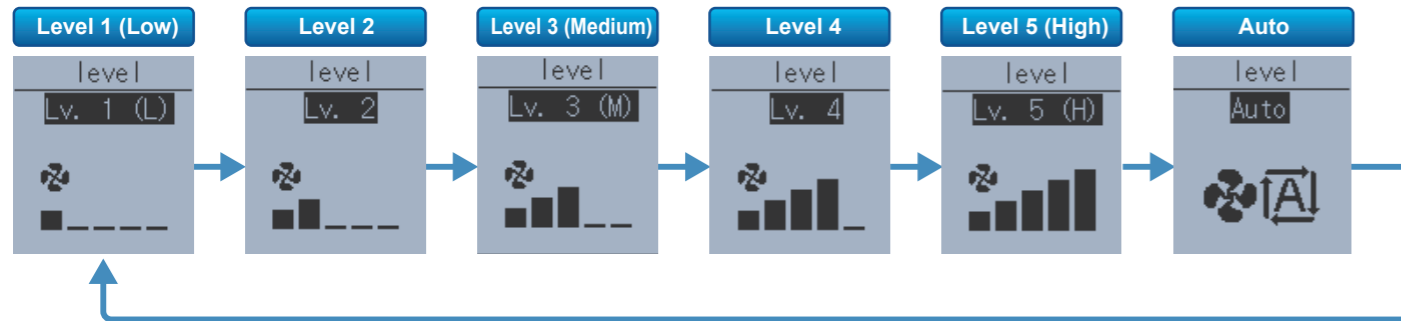
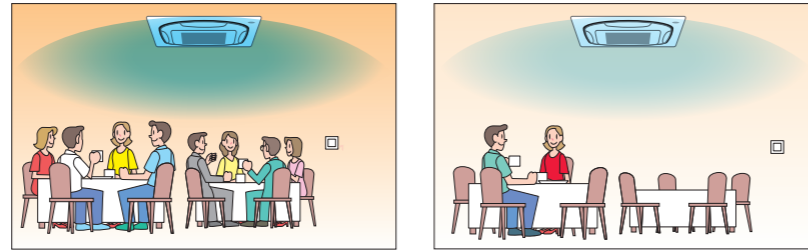

### Also convenient for high ceilings and spaces with long blow distances

Cassette type <Round Flow>:  
maximum 4.2 m\*

Ceiling suspended type:  
maximum 4.3 m

\*Field setting with remote controller

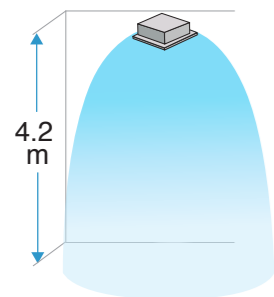

See page 29

\*Maximum 4.2 m for FCF100, 125, 140  
Maximum 3.5 m for FCF50, 60, 71

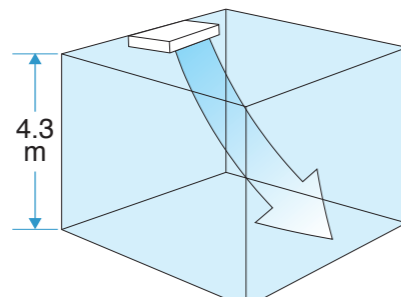

See page 40



## More Economy or Comfort in Special Situations

RZF series only

### High sensible cooling enables even greater power savings

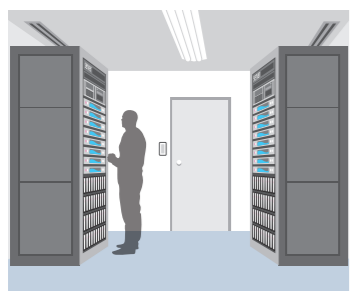

In locations such as simple server rooms, dehumidification is not required and greater power savings are possible with 'High sensible cooling' mode.

\*Available with RZF-C series.  
Field setting with remote controller.

### High dehumidification cooling provides even greater comfort



In restaurants and other spaces where many people gather, 'High dehumidification cooling' mode reduces humidity and creates greater comfort.

\*Available with RZF100-140CVM,  
71-140CYM models.  
Field setting on outdoor unit.

# Detail of Each Product Specification

CEILING MOUNTED CASSETTE TYPE <Round Flow>	FCF-C Series		Page 23
COMPACT MULTI FLOW CEILING MOUNTED CASSETTE TYPE	FFF-B Series		Page 33
CEILING MOUNTED SLIM DUCT TYPE	FDF-B Series		Page 35
DUCT CONNECTION MIDDLE STATIC PRESSURE TYPE	FBA-B Series		Page 37
CEILING SUSPENDED TYPE	FHA-B Series		Page 39
FLOOR STANDING TYPE	FVA-A Series		Page 41
OUTDOOR UNIT	RZF-C Series RZA-B Series		Page 43
REMOTE CONTROLLER			Page 45



# Cassette air conditioner with 360° uniform airflow sets the standard



Option  
Accessory required for indoor unit.

### Navigation Remote Controller

(Wired Remote Controller)



**BRC1E63**

Note: Remote controller cable is not included and must be obtained locally.

### Wireless LCD remote controller

A signal receiver must be added to the indoor unit.



- Cooling only **BRC7M635F** (Fresh white)
- BRC7M635K** (Black)
- Heat pump **BRC7M634F** (Fresh white)
- BRC7M634K** (Black)



Signal receiver unit (Installed type) Wireless remote controller is supplied in a set with a signal receiver.

### Panel variations

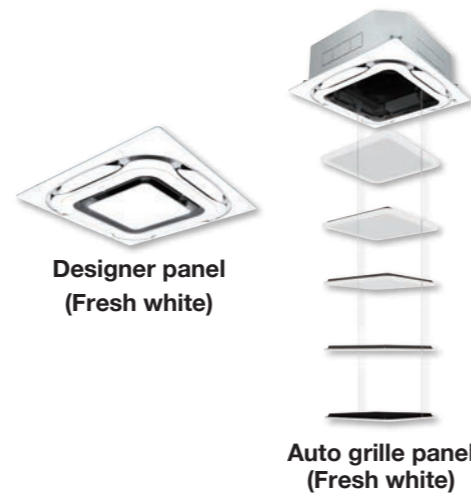

## Circulation Airflow

Cools the entire room to deliver comfort that never feels cold.

Cooling operation repeatedly performs the following at start.

- 2-way horizontal flow
- 4-way swing flow
- 2-way horizontal flow (direction changes)
- 4-way swing flow

Heating operation repeatedly performs the following at start.

- 2-way horizontal flow
- 4-way down flow
- 2-way horizontal flow (direction changes)
- 4-way down flow

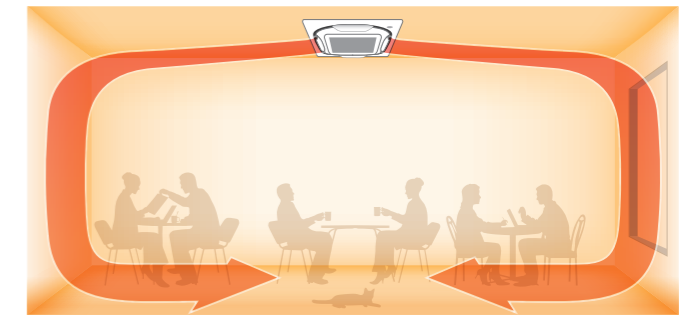
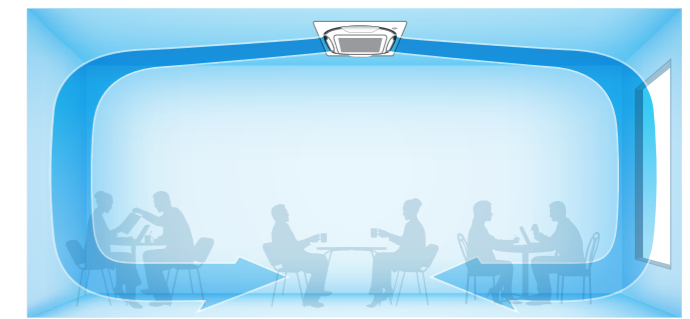

## Individual Airflow Direction Control

Airflow direction can be individually adjusted for each air discharge outlet to deliver optimal air distribution that conforms to conditions for airflow direction (small and large loads)  
Selectable from position 0 to 4, swing, and no individual setting.

Example



## 360° Airflow

With uniform temperature distribution

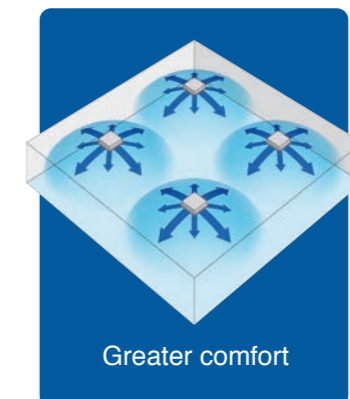

Airflow distribution creates uniform comfort throughout the space.

Room remains comfortable even when set temperature is raised 1°C.

## Selectable Airflow Pattern

Because air flows out from corner outlets, comfort spreads more widely.

### Typical flow patterns

There are a total of 18 flow patterns.

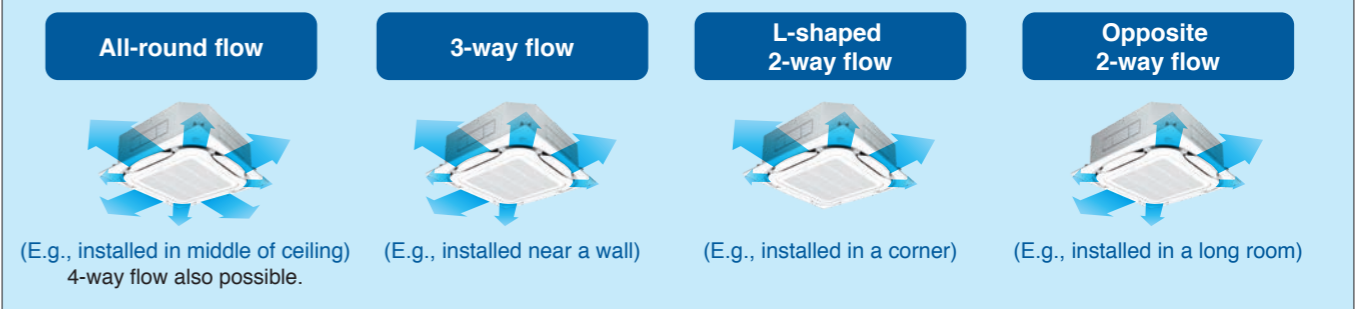

Required distance to wall surface for closing air discharge outlet

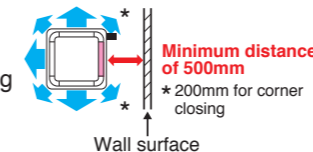

- Note:
- Whatever the discharge direction, the same type of panel is used. If installing for other than all-round flow, an air discharge outlet sealing material (option) must be used to close each unused outlet.
  - Operation sound increases when using 2-way or 3-way flow.
  - Designer panel cannot operate 2-way and 3-way flow.



# Daikin Sensing Technology\*1,2

\*1. Applicable when sensing panel (BYCQ125EEF/EEK) is installed.  
\*2. Applicable when wired remote controller BRC1E63 is used.

## Dual Sensors\*1

■ Dual sensors and individual airflow direction control automatically provide optimal control of airflow.

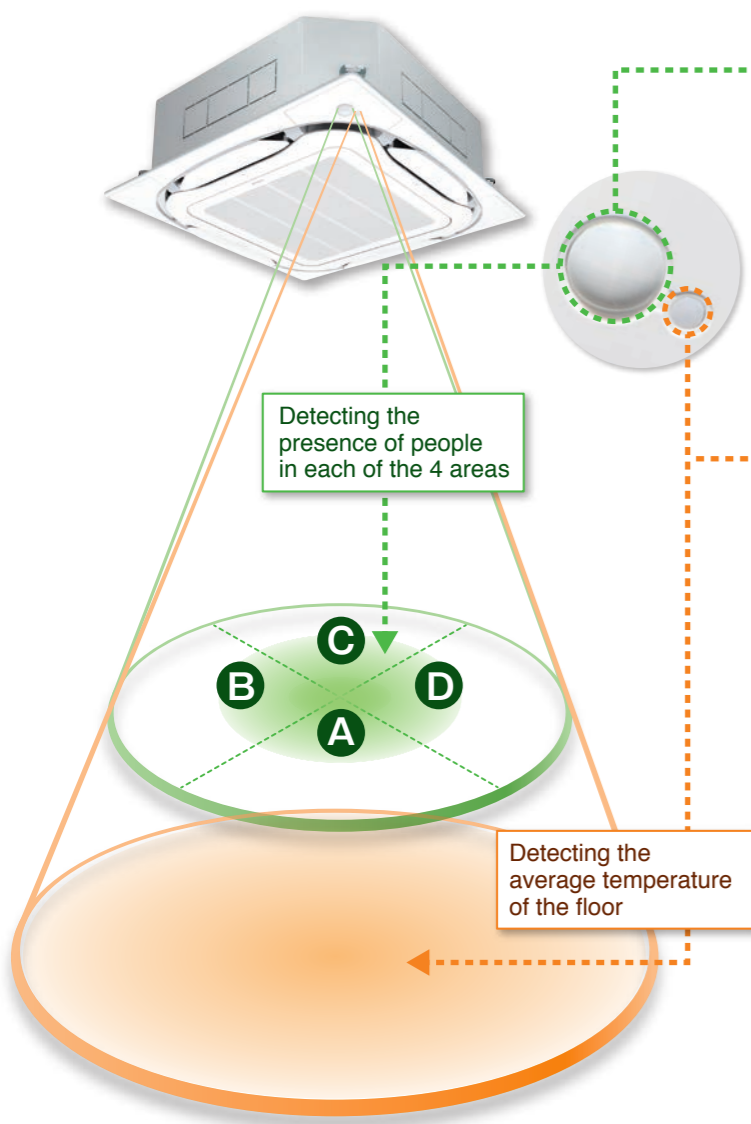

### Infrared presence sensor

The sensor detects the presence of people in each of the 4 areas.

Ceiling height	2.7m	3.5m	4.0m
Detection range (diameter) <sup>3</sup>	approx. 8.5m	approx. 11.5m	approx. 13.5m

<sup>3</sup>The infrared presence sensor detects 80cm above the floor.

### Infrared floor sensor

The sensor detects the floor temperature and automatically adjusts operation of the indoor unit to reduce the temperature difference between the ceiling and the floor.

Ceiling height	2.7m	3.5m	4.0m
Detection range (diameter) <sup>4</sup>	approx. 11m	approx. 14m	approx. 16m

<sup>4</sup>The infrared floor sensor detects at the floor surface.

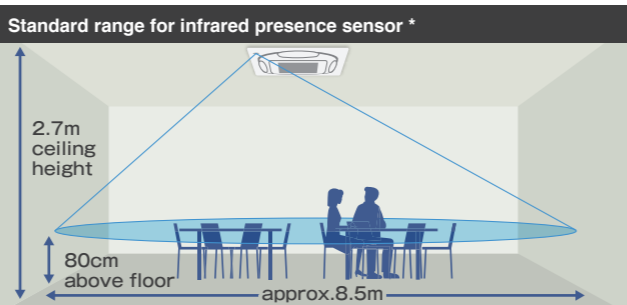

[Concerning infrared presence sensor]  
- People are detected by large movements such as the motion of people walking at a certain distance away from sensor.  
- Human detection is not possible for blind areas of sensor.

[Concerning infrared floor sensor]  
- The detected temperature may sometimes be affected by a heat source, window, or device emitting heat in the detection range.

## Auto Airflow Functions\*5

\*5. Airflow direction should be set to "Auto".

### Direct Airflow (default: OFF) Cooling Dry

When human presence is not detected

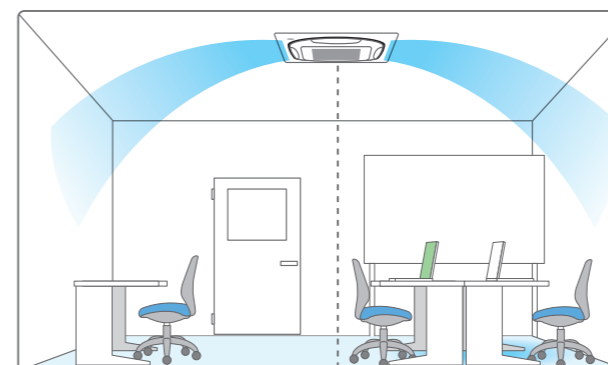

Optimal air direction by "Auto"

When human presence is detected

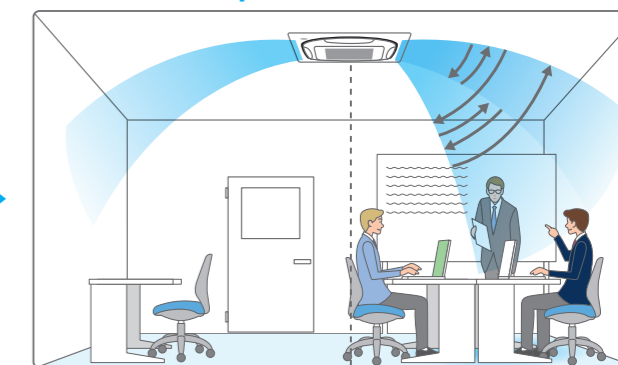

Optimal air direction by "Auto" **Swing (narrow)**

• With "Auto" airflow direction mode, flaps are controlled to deliver optimal airflow when the room is unoccupied.

• When presence is detected, air direction is set to "Swing (narrow)" to deliver cool air to users.

### Draft prevention (default: OFF) Heating

When human presence is not detected

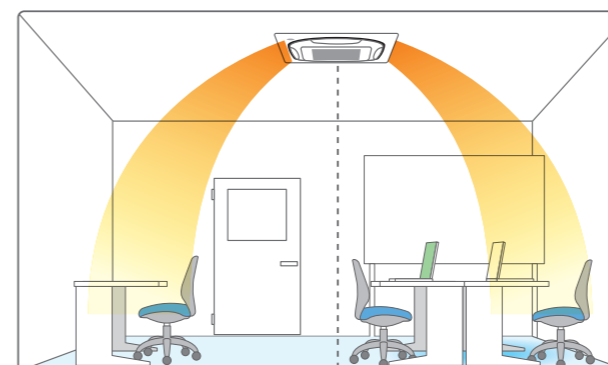

Optimal air direction by "Auto"

When human presence is detected

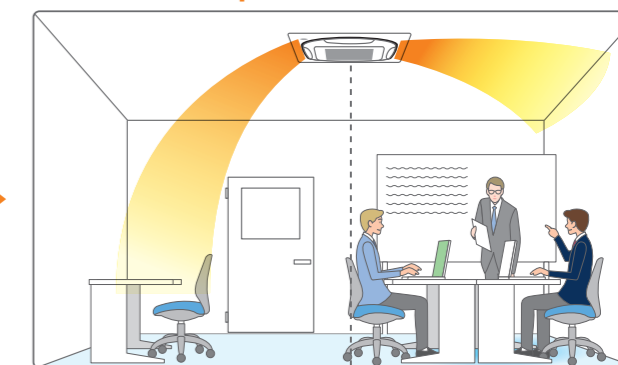

Optimal air direction by "Auto" **Blown horizontally**

• With "Auto" airflow direction mode, flaps are controlled to deliver optimal airflow when the room is unoccupied.

• When presence is detected, drafts are prevented by making the flap horizontal.

• When human is not detected for 5 minutes, the unit automatically returns to controlling the flaps for an unoccupied room.

# Daikin Sensing Technology\*1,2

\*1. Applicable when sensing panel (BYCQ125EEF/EEK) is installed.  
\*2. Applicable when wired remote controller BRC1E63 is used.

## Comfort and Energy Saving Preventing Overcooling / Overheating\*6

\*6. Airflow direction and airflow rate should be set to "Auto".

### ■ Floor temperature is detected and overcooling prevented. Cooling

**Without sensing function**

Area around feet gets too cold because the air conditioner continues until the temperature near the ceiling reaches the set temperature.

**With sensing function**

Room temperature is calculated as 27°C in the area which is in the vicinity of the person.

1. 24°C near floor

2. Room temperature is calculated as 27°C in the area which is in the vicinity of the person.

**Energy savings** The temperature near the person is automatically calculated by detecting the temperature of the floor. Energy is saved because the area around the feet does not get too cold.

The floor temperature, which is lower than near the ceiling, is detected.

Automatic control using the temperature near the person as the room temperature.

### ■ Feet are kept warm and comfortable while reducing uncomfortable drafts. Heating

**Without sensing function**

When air is blown horizontally...

Feet get cold, because warm air collects near the ceiling. Area near floor doesn't reach set temperature and feet feel cold.

For this reason, we end up raising the temperature setting.

**With sensing function**

The floor temperature, which is lower, is detected and warm air is blown downward where there is no human presence.

In order to reduce drafts, air is blown horizontally where a person is located.\*7

**Energy savings** The tendency of people to raise the temperature too much is prevented, because you are warmed up from the feet.

Comfortable because draft is reduced and area around feet is warm.

\*7. Draft prevention function is set OFF in the initial setting.

To increase comfort, Auto airflow rate mode controls the airflow in accordance with the difference between floor and ceiling temperatures.

When there is a large difference between the ceiling and floor temperatures, the airflow rate is automatically increased. When the difference becomes small, the airflow rate is automatically reduced.

## Sensing Sensor Functions\*8,9

\*8. These functions are not available when using the group control system.  
\*9. User can set these functions with remote controller.

### ■ Sensing sensor low mode (default: OFF)

When there are no people in a room, the set temperature is shifted automatically.

- The system automatically saves energy by detecting whether or not the room is occupied. The set temperature is shifted automatically if the room is unoccupied.

Operation is reduced in places where there are no people.

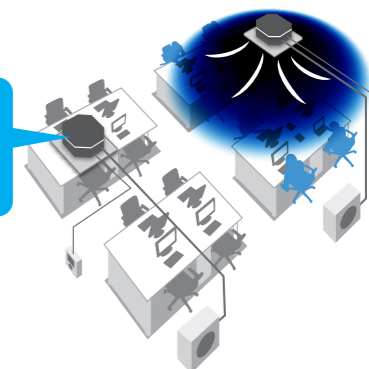

**Example** • Cooling set temperature: 26°C • Shift temperature: 1.0°C  
• Shift time: 30 min. • Limit cooling set temperature: 30°C

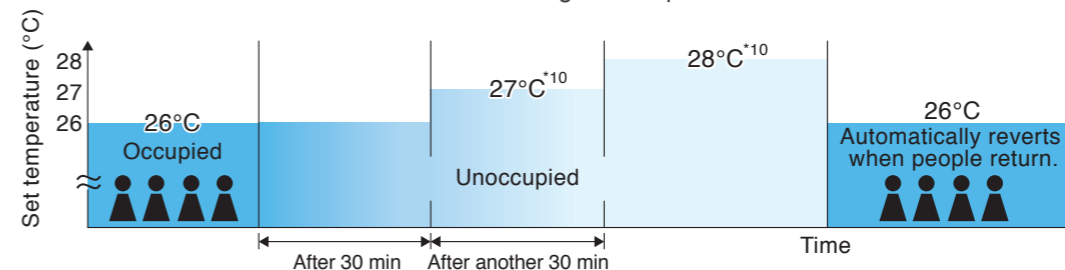

If people do not return, the air conditioner will raise the set temperature 1°C every 30 minutes and then operate at 30°C.

**Example** • Heating set temperature: 20°C • Shift temperature: 1.0°C  
• Shift time: 30 min. • Limit heating set temperature: 16°C

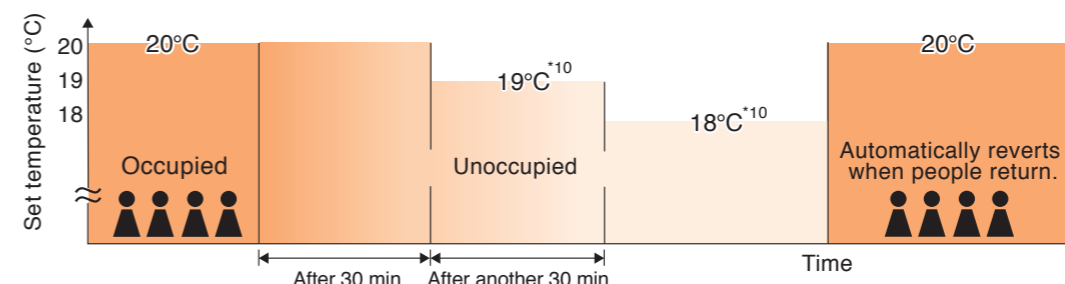

If people do not return, the air conditioner will lower the set temperature 1°C every 30 minutes and then operate at 16°C.

Shift temperature and time can be selected from 0.5 to 4°C in 0.5°C increments and 15, 30, 45, 60, 90 or 120 minutes respectively with remote controller.

\*10. On basic screen of remote controller, set temperature does not change.

### ■ Sensing sensor stop mode (default: OFF)

When there are no people in a room, the system stops automatically.\*11,12

- The system automatically saves energy by detecting whether or not the room is occupied.
- Based on preset user conditions, the system automatically stops operation if the room is unoccupied.

Absent stop time can be selected from 1 to 24 hrs in 1 hr increments with remote controller.

\*11. Please note that upon re-entering the room, the air conditioner will not switch on automatically.  
\*12. To protect the machine, the standby system may operate temporarily.

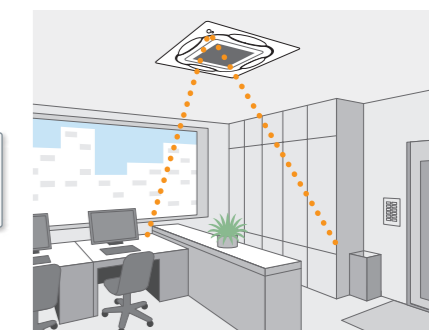

## Comfort

### Unified square panels

Panel size is the same for all models. It is easy to maintain a neat appearance when multiple units are installed in the same room.

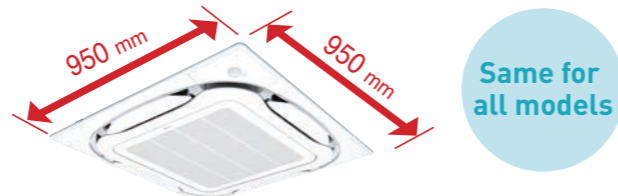

### Optimal comfort and convenience assured by 3 air discharge modes

Air direction	Standard setting <sup>1</sup>	Draft prevention setting (field setting)	Ceiling soiling prevention setting <sup>2</sup> (field setting)
Desired situation	For gentle drafts.	When drafts are unwanted.	For shops with light coloured ceilings that must be kept spotless.
Auto-swing			
5-level air direction setting			
Draft prevention (In heating mode)		At heating startup and thermo OFF, air discharge is automatically set to a near horizontal to prevent direct exposure to cool air drafts.	
Auto air direction control		The air direction is set automatically to the memorised position of the previous air direction.	

Note:  
<sup>1</sup>Air direction is set to the standard position when the unit is shipped from the factory. The position can be changed from the remote controller.  
<sup>2</sup>Closing of the corner discharge outlets is recommended.

### Switchable fan speed: 5 steps and Auto

Control of airflow rate has been improved from 3-step to 5-step. Auto airflow rate is newly available.

### Quiet operation

Indoor unit	Sound pressure level				
	H	HM	M	ML	L
50-71C	37.0	34.5	32.0	29.5	27.5
100C	45.0	41.5	38.0	35.0	32.5
125/140C	46.0	43.0	40.0	36.0	32.5

### Suitable for high ceilings

Even in spaces with high ceilings, a comfortable airflow is carried down to the floor level.

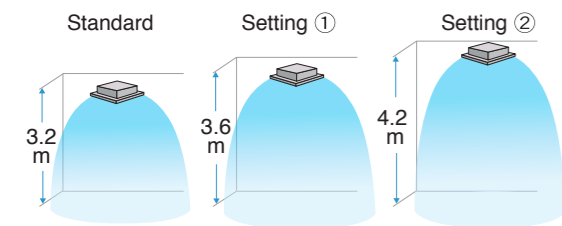

When all round flow is selected, ceilings up to 4.2 m in height can be accommodated. (100-140C)

### Criteria for ceiling height and number of air discharge outlets (Ceiling height is reference value)

Ceiling height	Standard	Number of air discharge outlets used							
		50-71C				100-140C			
		All round flow	4-way flow	3-way flow	2-way flow	All round flow	4-way flow	3-way flow	2-way flow
Standard	2.7 m	3.1 m	3.0 m	3.5 m	3.2 m	3.4 m	3.6 m	4.2 m	
High ceiling ①	3.0 m	3.4 m	3.3 m	3.8 m	3.6 m	3.9 m	4.0 m	4.2 m	
High ceiling ②	3.5 m	4.0 m	3.5 m	—	4.2 m	4.5 m	4.2 m	—	

Note:  
 • The aforementioned is for standard panels. See the installation manual for designer panels.  
 • Factory settings are for standard ceiling height and all-round flow.  
 • High ceiling settings (1) and (2) are set with the remote controller by field setting.  
 • High-efficiency filters are not available for high ceiling applications.

## Cleanliness

### Silver ion anti-bacterial drain pan

A built-in antibacterial treatment that uses silver ion in the drain pan prevents the growth of slime, bacteria, and mould that cause odours and clogging. (The lifespan of a silver ion cartridge depends on the usage environment, but should be changed once every two to three years.)



### Non-flocking flaps

Flaps can be detached without use of tools. Condensation does not easily form and dirt does not cling to non-flocking flaps. They are easy to clean.



### Filter has anti-mould and antibacterial treatment

Prevents mould and microorganisms growing out of the dust and moisture that adheres to the filters.

## Quick and Easy Installation

### Lightweight

All models can be installed without using a lifter.

### Installable in tight ceiling spaces

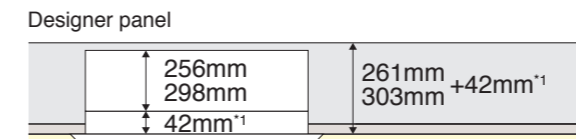
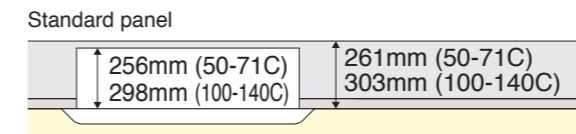

\*1. Body height (ceiling required space) is 42 mm higher than standard panel.

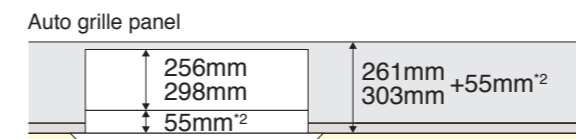

\*2. Body height (ceiling required space) is 55 mm higher than standard panel.

\*When the ceiling space is limited, an optional panel spacer is available. (see P.32)

### Easy height adjustment

Each corner of the unit has an adjuster pocket that lets you easily adjust the unit's suspended height.

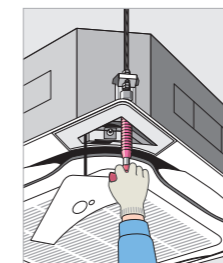

Note:  
 If the wireless remote controller is installed, a signal receiver unit is housed in one of the adjuster pockets.

### Temporary placement of control box lid

Because the control box lid can be temporarily hung on the unit, there is no need to climb down the stepladder to retrieve it.

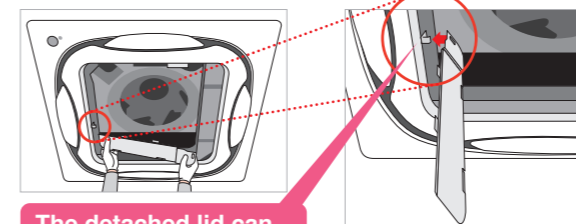

The detached lid can be hung on a hook.

### Installed in any direction

Since the orientation of the suction grille can be adjusted after installing, the direction of the suction grille lines can be unified when multiple units are installed.

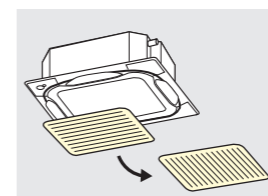

### Easy hanging

Washer fixing plates secure washers in place and prevent washers from falling for easy installation.

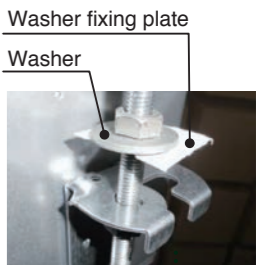

### Easy removal of corner cover

It is possible to easily remove without use of screws or tools.

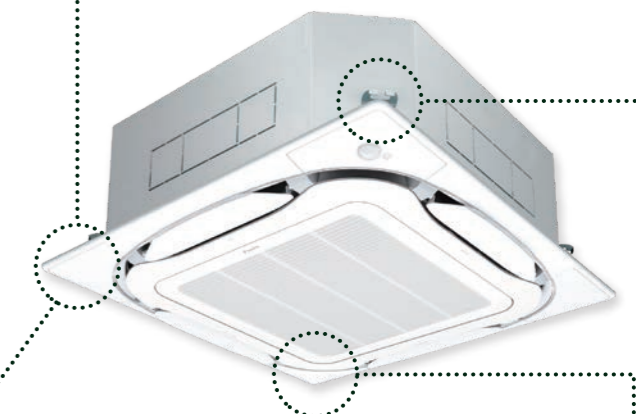

### Ease in temporary hanging of decoration panel

In addition to the temporary hanging fixtures in 2 places normally used, corner part mounting fixtures in 4 places are provided.

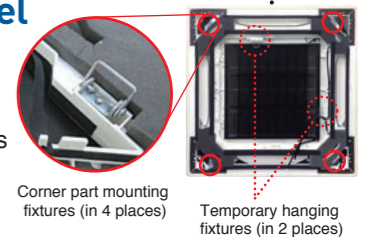

### Drain pump

Equipped as standard accessory with 850 mm lift.

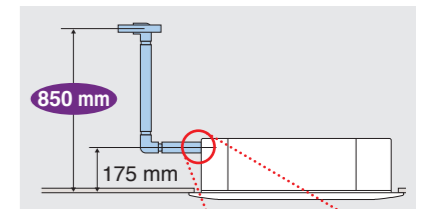

### Transparent drain socket



### Hanging height adjustment

Because the configuration of the hanger bracket changed, the dimensions from the ceiling to the hanger bracket also change during height adjustment for indoor unit.

	A Dimensions
Standard panel	125-130mm
Designer panel	167-172mm
Auto grille panel	180-185mm
Chamber option*+ standard panel	175-180mm

\*High-efficiency filter, ultra long-life filter, and fresh air intake



## Easy Maintenance

### Condition of the drain pan and drain water

Can be checked by removing the suction grille and drain plug.

Note: For inquiries concerning auto grille panel installations, please contact your local dealer or Daikin representative.

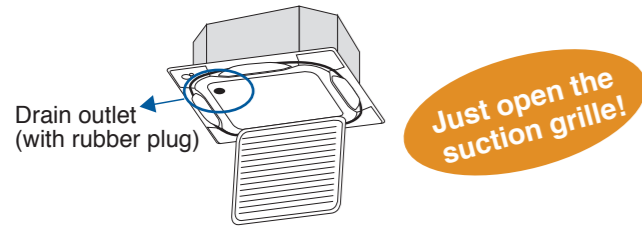

### 24 mm diameter drain outlet

The drain outlet allows insertion of a finger or dental mirror for inspection of the internal cleanliness of the drain pan. Removal of the suction panel enables access.

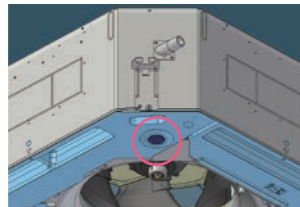

### Auto grille panel (option)

Grille and air filter cleaning can be performed without need for a stepladder by lowering the grille.

A dedicated remote controller for the auto grille panel (BRC16A2) is included.  
Operation is not possible using BRC1E63.

The drop length corresponds to ceiling height and can be set for 8 different levels.

Ceiling Height Standard (m)	Drop Length
2.4	1.2
2.7	1.6
3.0	2.0
3.5	2.4
3.8	2.8
4.2	3.1
4.5	3.5
5.0*	3.9

\*Airflow range is up to 4.5m. Please refer to "criteria for ceiling height and number of air discharge outlets" on page 25.



### Ultra long-life filter (option)

See page 32

Maintenance is not required in normal shops or offices for up to four years.

### Low gas pressure detection



## Options

Options required for specific operating environments

### Ultra long-life filter unit

Even in dusty environments where the air conditioning is constantly operating, the ultra long-life filter only has to be cleaned once a year.

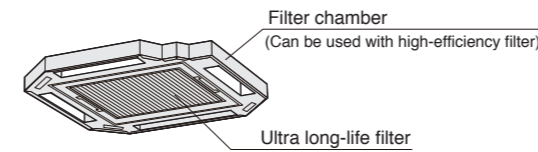

#### Dusty area: annual filter change

\*For dust concentration of 0.3 mg/m<sup>3</sup> (Requires separately sold Air purifier.)  
1 year (Approx. 5,000 hr) ≈ 15 hr/day x 28 day/month x 12 month/year

#### Ordinary store or office: filter change every 4 years

\*For dust concentration of 0.15 mg/m<sup>3</sup>  
4 years (Approx. 10,000 hr) ≈ 8 hr/day x 25 day/month x 12 month/years x 4 years

### High-efficiency filter unit

Available in two types: 65% and 90% colorimetry.

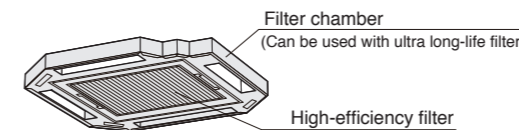

### Insulation kit for high humidity

Please use if you think the temperature and humidity inside the ceiling exceeds 30°C and RH 80%, respectively.

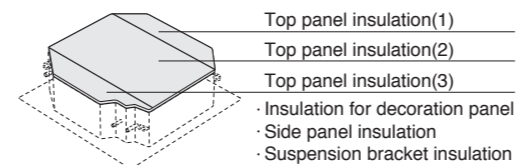

### Panel spacer

Use when only minimal space is available between drop ceilings and ceiling slabs.

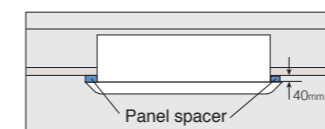

Note: Some ceiling constructions may hinder installation. Contact your Daikin Dealer before installing your unit.

### Sealing material of air discharge outlet

Sealing material block air discharge openings not used in 2-way or 3-way blow.

### Branch duct chamber

This chamber lets you connect a round flexible duct to the air discharge opening at any time after the original installation.

### Fresh air intake kit Note 1.2

Using this kit, a duct can be connected to take in outdoor air. There are two chamber types that have intake in two places: with T-duct joint and without T-duct joint.

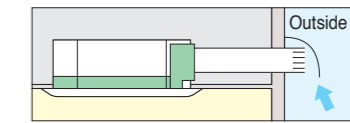

### The units can be installed in the following different ways

#### Chamber type (without T-duct joint) Note 3.4.5

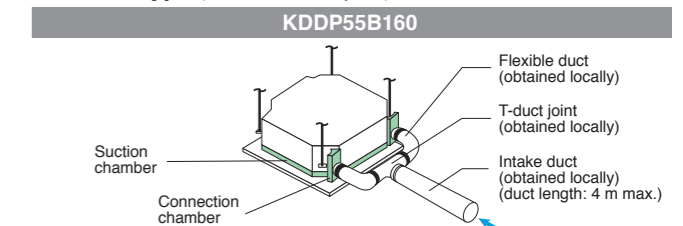

#### Chamber type (with T-duct joint) Note 3.4.5

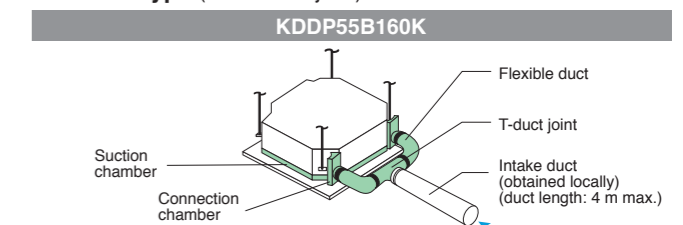

#### Direct installation type Note 6

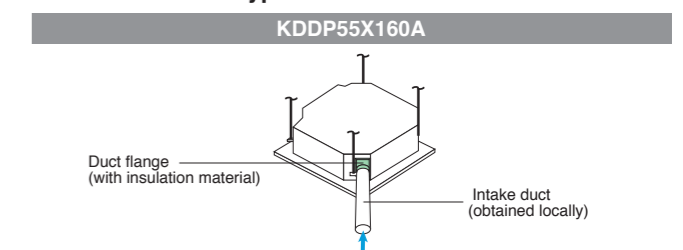

- Note:
1. Use of options will increase operating sound.
  2. Connecting ducts, fan, insect nets, fire dampers, air filters, and other parts should, as required, be obtained locally.
  3. When a local-obtained fan is used, an interlock with air conditioner is necessary. Optional PCB (KRP1C11A) is required for interlocking.
  4. When installing a fresh air intake kit (chamber type), two air outlet corners are closed.
  5. It is recommended that the volume of outdoor air introduced through the kit is limited to 10% of the maximum airflow rate of the indoor unit. Introducing higher quantities will increase the operating sound and may also influence temperature sensing.
  6. The volume of fresh air for direct installation type is approximately 1% of the indoor unit airflow. The chamber type is recommended when more fresh air is necessary.

# Quiet and decorative style that easily installs in new or old buildings



FF50/60BV1

**Option**  
Accessory required for indoor unit.

**Navigation Remote Controller**  
(Wired Remote Controller)

**BRC1E63**

Note: Remote controller cable is not included and must be obtained locally.

**Wireless LCD remote controller**  
A signal receiver must be added to the indoor unit.

Cooling only **BRC7E531W**

Signal receiver unit (Installed type)  
Wireless remote controller is supplied in a set with a signal receiver.

## Compact

- Sized to fit inside 600mm wide ceiling grids

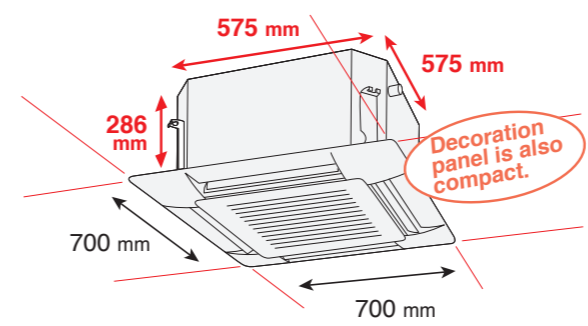

- Fits without the need to cut T-bar grid

The control box is built in to the unit, so maintenance is possible by simply removing the grille. An inspection opening is not required even for modules other than 600 mm x 600 mm.

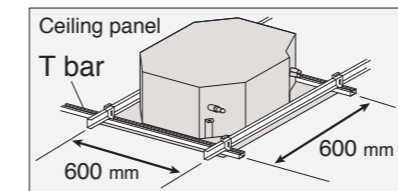

## Quiet Operation

- Quiet, but small-diameter fan

Quiet operation is achieved even with a compact body and developed spiral hub cover that reduces the static pressure inside the indoor unit.



Indoor unit	Sound pressure level	
	High	Low
50/60B	41	32

dB(A)

## Comfort

- Designed for low draft performance

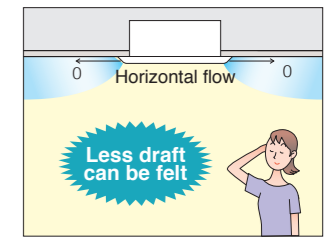

- Consistent comfort throughout

- Auto-swing operation distributes conditioned air more evenly.
- Airflow direction can be adjusted in accordance with room conditions.

	Auto-swing	5-levels air direction setting
Standard setting	Auto-swing between 0 and 60	Settable to 5 different levels between 0 and 60
Draft prevention setting (Set on site)	Auto-swing between 0 and 35	Settable to 5 different levels between 0 and 35
Setting to prevent soiling of ceiling (Set on site)	Auto-swing between 25 and 60	Settable to 5 different levels between 25 and 60

Note: This angle above is provided as a guide.

- Multi-Flow System

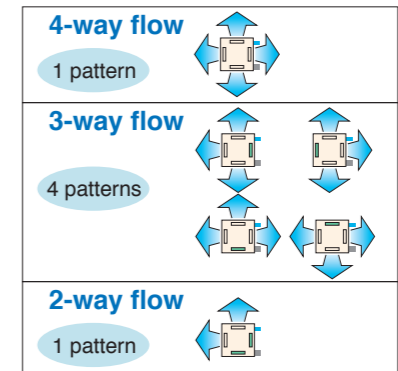

- Air direction can be selected according to installation.

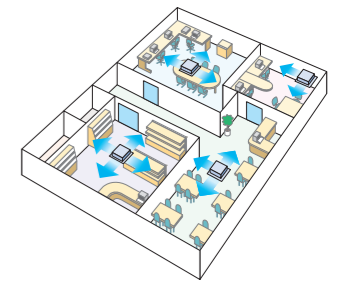

Note: Operation sound increases when using 2-way or 3-way flow.

"■" denotes piping direction.  
 ■ Drain piping "■" denotes sealing material for air discharge outlet (option).

Note:  
 For 3-way or 2-way flow installation, the sealing material for air discharge outlet (option) must be used to close off the unused outlet(s).

- Two selectable temperature-sensors

Both indoor unit and wired remote controllers contain temperature-sensors. Temperature sensing can be set at the unit or, to further improve comfort level, closer to the target area at the wired remote control. This feature requires initial setting by the installer.

\*Temperature-sensor on indoor unit must be used when the air conditioner is controlled from another room.  
 \*\*Wireless remote controller does not have a temperature-sensor.

- Switchable fan speed: High/Low

High setting provides maximum reach while low setting minimizes drafts.

- Drain pump

Equipped as standard accessory with 750 mm lift.

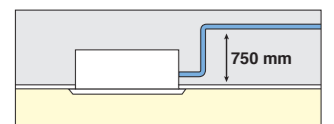

# Suitable for tight ceiling spaces



**FDF50/60BV1**

Note: Refer to engineering data for airflow and external static pressure characteristics.

**Option**  
Accessory required for indoor unit.

**Navigation Remote Controller**  
(Wired Remote Controller)

**BRC1E63**

Note: Remote controller cable is not included and must be obtained locally.

**Standard**

**Wireless LCD remote controller**  
A signal receiver must be added to the indoor unit.

Cooling only **BRC4C64**

Signal receiver unit (Separate type)

Wireless remote controller is supplied in a set with a signal receiver.

## Compact and Slim Design

Only 200 mm high

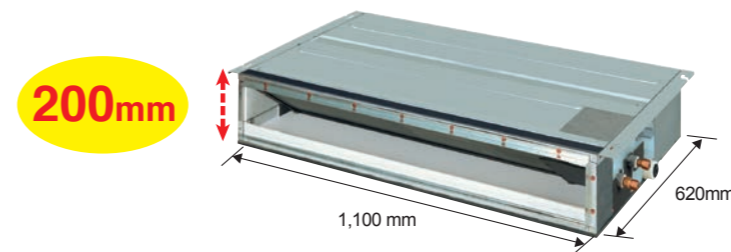

Easily installed in even shallow ceiling cavity with a height of just 240 mm.

Indoor unit	FDF50B	FDF60B
Height	200 mm	
Width	1,100 mm	
Depth	620 mm	
Weight	30 kg	

## Bulkhead Installation

The slim duct type can be hidden inside the ceiling to provide a clean exterior. It is suitable for living rooms with shallow tray ceilings or areas requiring a discreet appearance. FDF-B series are 900 and 1,100 mm wide, making them ideal for narrow spaces.

All models are 200 mm high and require a space of only 240 mm between the drop ceiling and ceiling slab. With these compact measurements, any unit can easily be installed in even shallow tray ceilings.

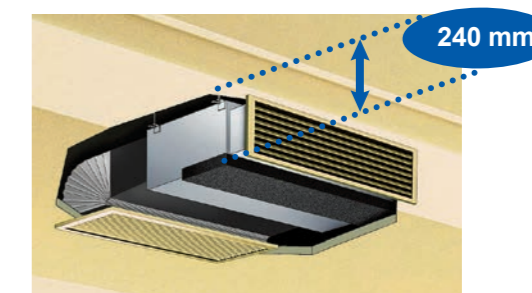
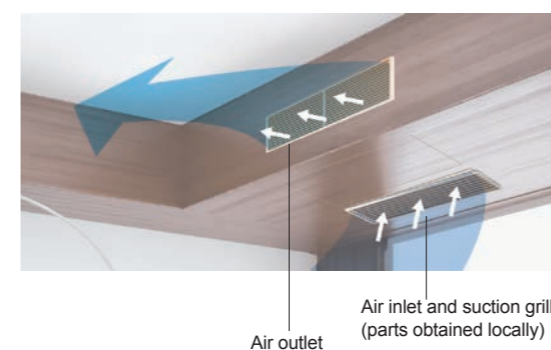

## Smooth Finish

The only visible sign of these unobtrusive units is their discharge grilles. They fit completely inside the ceiling to maintain the original decor of a room.

## Quiet Operation

Indoor unit	Sound pressure level	
	H	L
50/60B	38	34

dB(A)

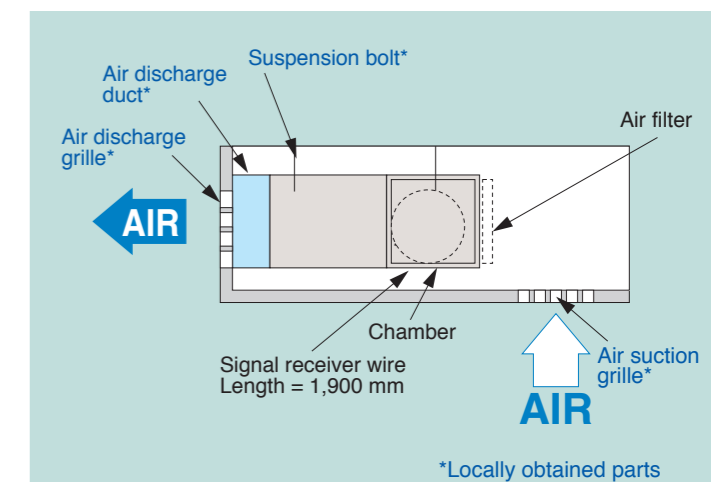

Note:

- To prevent an increase in operation sound, avoid installing the air suction grille directly below the suction chamber.
- Grilles, piping connections, ducts, and installation parts should be obtained locally. Duct-connected types do not have drain pumps.

# Thinner design allows greater installation flexibility

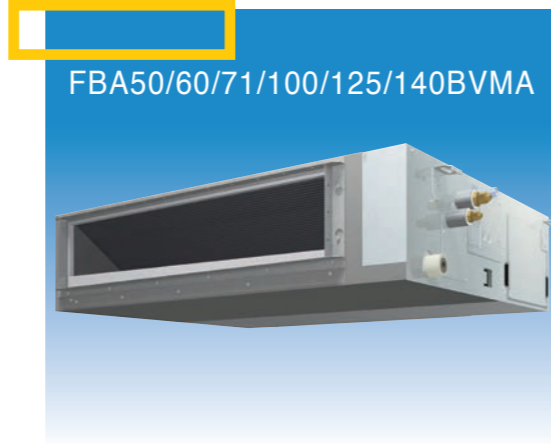

FBA50/60/71/100/125/140BVMA

Option

Accessory required for indoor unit.

## Navigation Remote Controller

(Wired Remote Controller)



BRC1E63

Note: Remote controller cable is not included and must be obtained locally.

## Wireless LCD remote controller

A signal receiver must be added to the indoor unit.



Cooling only BRC4C66

Heat pump BRC4C65



Signal receiver unit (Separate type)

Wireless remote controller is supplied in a set with a signal receiver.

### Simultaneous air conditioning of two rooms and ventilation grille (ventilation opening)

When air conditioning two rooms simultaneously, the air discharged into each room must be circulated back to the air conditioner. To achieve this, a ventilation duct should be installed for each room or one of the indicated ventilation grilles should be installed on the partitioning wall or under the door between the rooms.

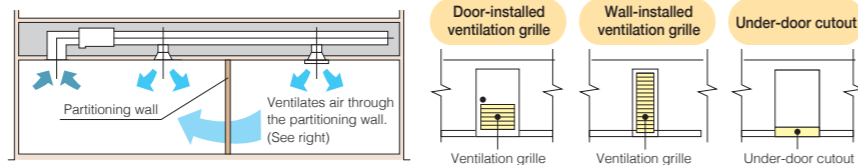

Note: The under-door cutout method should be used only when there is a small volume of airflow.

## Design and Installation Flexibility

### Only 245 mm high

Installation is possible even in buildings with narrow ceiling spaces.



One of the industry's most compact bodies in the mid-static pressure range.

Indoor unit	50/60/71B	100/125/140B
Height (mm)	245	
Width (mm)	1,000	1,400
Depth (mm)	800	

### Higher lift is realized

A built-in DC drain pump with standard accessory is utilised.

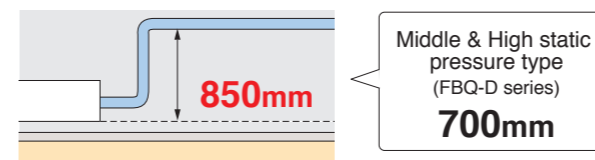

### Bottom suction is available

Wiring and servicing can be done from the underside of the unit (an option part required).

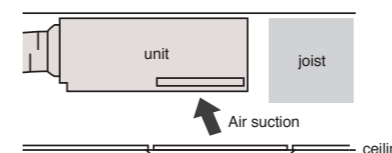

Rear suction

Bottom suction

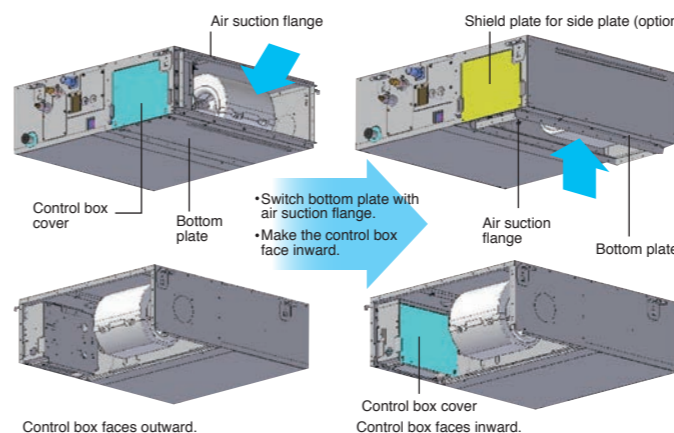

## Comfort

### Switchable fan speed: 3 steps and Auto

"Auto" is applicable when BRC1E63 is used.

## Clean

### Silver ion anti-bacterial drain pan

A built-in antibacterial treatment that uses silver ion in the drain pan prevents the growth of slime, bacteria, and mould that cause odours and clogging. (The lifespan of a silver ion cartridge depends on the usage environment, but should be changed once every two to three years.)



### Adjustable E.S.P.

External static pressure can be controlled to within a range of 50 Pa to 150 Pa by using a DC fan motor.



Set to low static pressure when ducts are short.

Set to high static pressure for advanced needs such as when using dampers and long ducts.

Comfort airflow is achieved in accordance with conditions such as duct length.

### Airflow rate auto adjustment function

Controls the airflow rate using a remote controller during test run. It is automatically adjusted to approximately  $\pm 10\%$  of the rated H tap airflow.

### Interlock control

As an energy saving feature, the room air conditioning unit can be interlocked with the hotel key card system. Using a 3rd-party building management system, air conditioning and lighting can be interlocked.

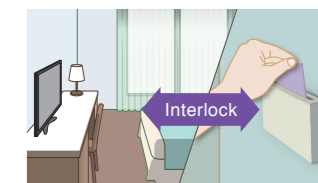

\* Field setting with remote controller

### DIII-NET communication standard

Connection to a centralised control system is available without need for an optional adaptor.

## Easy Maintenance

### Position of drain pan inspection opening

Modified for easier inspection work.

### Drain pan maintenance check window

This makes it possible to inspect for drain pan dirt and to confirm drainage during installation without the use of tools.

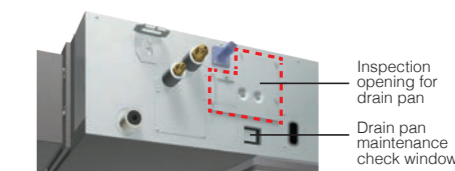

## High Efficiency

### DC fan motor and DC drain pump

These are utilised to improve energy efficiency.

# Comfortable airflow travels throughout the room



FHA50/60/71/100BVMV  
FHA125/140BVMA



**Option**

Accessory required for indoor unit.

**Navigation Remote Controller**

(Wired Remote Controller)



**BRC1E63**

Note: Remote controller cable is not included and must be obtained locally.

**Wireless LCD remote controller**

A signal receiver must be added to the indoor unit.



Cooling only **BRC7M56**

Heat pump **BRC7M53**



Signal receiver unit (Installed type)  
Wireless remote controller is supplied in a set with a signal receiver.

**Stylish Model**

- **Sophisticated design**  
Flap neatly closes when not in use.
- **White colour**



**Comfort**

- **The technology of the DC fan motor, wide sirocco fan, and large heat exchanger combine for greater airflow and quiet operation**
- **Auto swing (up and down) and louvers (left and right by hand) bring comfort to the room**
- **Louver manually adjusts for straight or wide angle airflow**

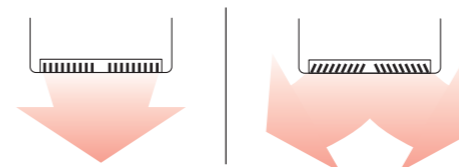

- **Suitable for high ceilings**

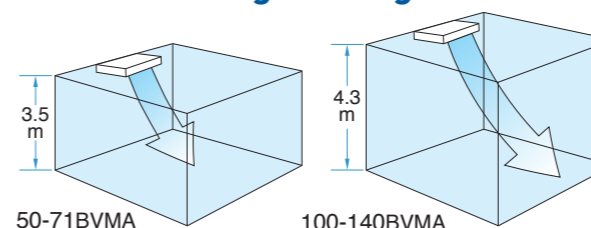

	50-71B	100B	125/140B
Standard	2.7m or less	3.8m or less	4.3m or less
High ceiling	2.7m-3.5m	3.8m-4.3m	—

Note: Factory settings is "standard".  
"High ceiling" are set with remote controller by field setting.

- **Switchable fan speed: 5 steps and Auto**  
Control of airflow rate has been improved from 3-step to 5-step. Auto airflow rate is newly available.

**Quiet Operation**

Indoor unit	Sound pressure level dB(A)				
	H	HM	M	ML	L
50/60B	37.0	36.0	35.0	33.5	32.0
71B	38.0	37.0	36.0	35.0	34.0
100B	42.0	40.0	38.0	36.0	34.0
125B	44.0	42.5	41.0	39.0	37.0
140B	46.0	44.0	42.0	40.0	38.0

**Installation Flexibility for Freedom of Design**

- **Flexible installation**

The unit fits more snugly into tight spaces.

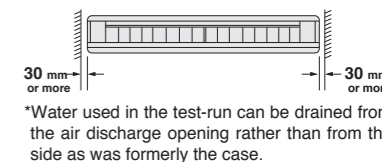

- **Drain pump kit (option) can be easily incorporated**

Drain pipe connection can be done inside the unit. Refrigerant and drain pipe outlets are at the same opening.

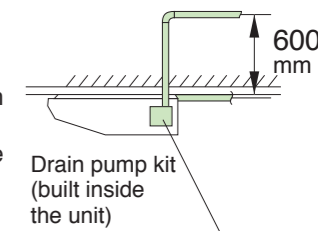

- **DIII-NET communication standard**

Connection to a centralised control system is available without need for an optional adaptor.

- **All wiring and internal servicing can be done from under the unit**

- **Easier piping work for rear side by removable frame**

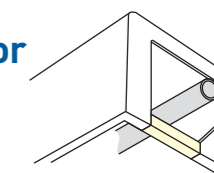

**Easy Maintenance**

- **Drain pump kit (option) includes a silver ion antibacterial agent**

That assists in preventing the growth of slime, bacteria, and mould that cause odours and clogging.

- **Non-flocking flap**

Condensation does not easily form and dirt does not cling to non-flocking flap. It is easy to clean.

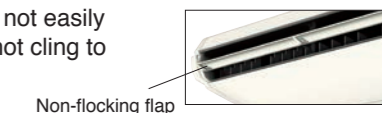

- **Easy-clean, flat surfaces**

It is easy to wipe dirt off the flat side and lower surfaces of the unit.

**Oil Resistant Grille**

- **Oil-resistant plastic is used for the air suction grille.**

This satisfies durability in restaurants and other similar environments.

Note: Intended for use in salons, dining rooms, and ordinary sales floors, this specification is not suitable for kitchens or other harsh environments.

# New airflow control for more comfort



BRC1E63 can be incorporated into the indoor unit.

**Option**  
Accessory required for indoor unit.

### Navigation Remote Controller

(Wired Remote Controller)



**BRC1E63**

Note: Remote controller cable is not included and must be obtained locally.

### Wireless LCD remote controller

A signal receiver must be added to the indoor unit.



Cooling only **BRC4C66**



Signal receiver unit (Separate type)

Wireless remote controller is supplied in a set with a signal receiver.

- This product is equipped with a gas sensor. The gas sensor reacts to nearby smoke, chemical agents, and paint as well as equipment containing flammable gas (including propane, butane, or methane), and sprays using flammable gases (such as LPG), including insecticides and hair spray. When this occurs, a malfunction is displayed and operation is not possible.
- A gas sensor that has once reacted must be replaced with a new gas sensor.

## Comfortable Airflow Control

### Left and right directions (by remote controller) (Applicable when BRC1E63 is used.)

Auto swing direction is selectable from 3 patterns to suit the layout of the room.

#### Pattern 1 Swing wide across the front

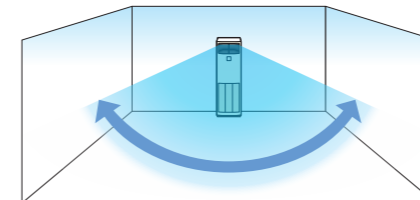

When installed in the center of a wall.

#### Pattern 2 Swing across left side

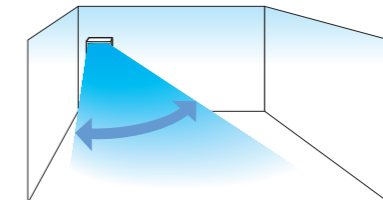

#### Pattern 3 Swing across right side

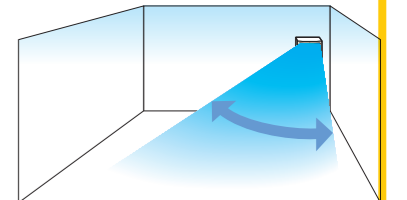

When installed in the corner of a room.

### Up and down directions (by hand)

Independent up-and-down airflow directions facilitate even room temperature and help save energy.

Freely select both up and down airflow direction with 8-louver (horizontal blade) setting.

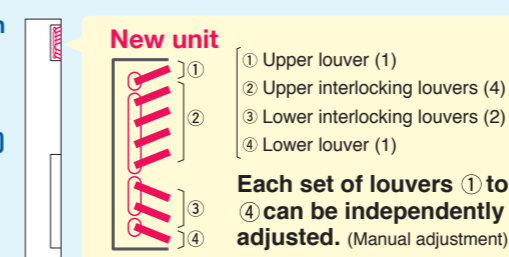

Example applications

#### When cooling

Turning louvers ① and ② upward and leaving ③ and ④ horizontal will reduce uneven room temperature.

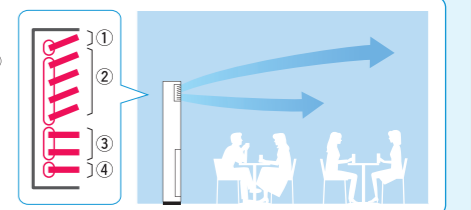

## Comfort

### Switchable fan speed: 3 steps and Auto

"Auto" is applicable when BRC1E63 is used.

### High fan speed mode (applicable for FVA50-100)

To carry airflow to the far side of the room, airflow rate can be increased 5% or 10% depending on the installation condition or customer's request. (Field setting by remote controller.)

### Programme "Dry"

Dehumidification is microprocessor controlled to prevent abrupt and uncomfortable changes in air temperature.

## High Efficiency

### DC fan motor improves efficiency

## Easy Installation

### Lightweight indoor unit

Enables smooth transport and installation of the indoor unit. (kg)

Indoor unit	50/60/71A	100/125/140A
Weight	42	50

### DIII-NET communication standard

Connection to a centralised control system is available without option.

## Easy Maintenance

### Long-life filter (standard) requires no maintenance for about 1 year\*

The filter is washable and reused after 1 year.

\* For dust concentration of 0.15 mg/m<sup>3</sup>

-Two time settings (2500 hrs and 1250 hrs) are available to match the installation environment. Maintenance time warning is displayed on the remote controller (filter sign).  
-The periodical cleaning time for the filter can be shortened depending on the usage environment.

### Employs a safety lock function of suction grille

The grille will not open even upon impact.

## Convenience

### Wireless remote controller (separate type) is supplied in a set with a signal receiver. (BRC4C66)

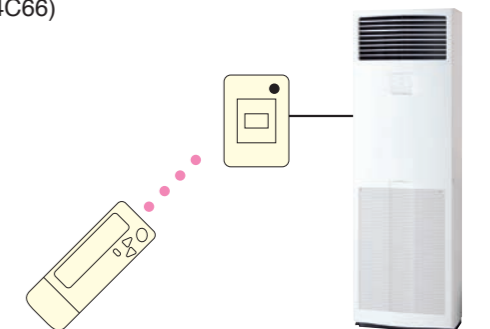



# Compact Outdoor Unit



## Easy Installation and Maintenance

### 4-direction piping offers greater layout freedom (RZF125-140C, RZA71/100B)

The outer panel for the piping connection part of the front, right side and backside can be removed and is easier for post-installation piping work.

### Removable part of bottom frame makes the piping work easier (RZF125-140C, RZA71/100B)

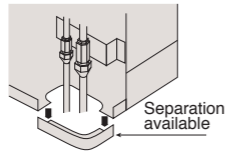

### Facilitates pump down (Refrigerant recovery function)

A pump-down switch is provided to make it easier to collect refrigerant if the unit is to be moved or layout modified.

\*Pump-down function is available for pre-charged refrigerant amount.  
\*Although pumping-down operation allows most of the refrigerant to be recovered in a short period of time, some refrigerant will remain inside the indoor unit and refrigerant piping.  
Using a refrigerant recovery machine, recover remaining refrigerant from the stop valve service port until the pressure falls to 0.09 MPa. (gauge pressure:-0.011MPa) or less.

### Low gas pressure detection function

Effective gas monitoring reduces the labor required for operation, maintenance, and repairs.

## Reuse of Existing Piping: Refrigerant Pipe Size Table

RZF series only

Outdoor Unit		Existing pipe size (Liquid / Gas)	6.4 / 12.7	6.4 / 15.9	9.5 / 12.7	9.5 / 15.9	9.5 / 19.1	12.7 / 15.9	12.7 / 19.1	Level difference	Design pressure (High pressure)
RZF 50-71CV2V	Condition		■	▲	■	◎	×	△	×	Max. 30m	4.15MPa
	Max. piping length	10m*	10m*	50m	50m	—	25m	—			
	Chargeless piping length	10m	10m	30m	30m	—	15m	—			
RZF 71CYM 100-140C	Condition		■	▲	■	◎	○	△	△	Max. 30m	4.15MPa
	Max. piping length	10m*	10m*	50m	50m	50m	25m	25m			
	Chargeless piping length	10m	10m	30m	30m	30m	15m	15m			

- ◎ Standard pipe size    ○ Same condition with standard pipe    △ Piping length and chargeless piping length are shortened
- ▲ Piping length and chargeless piping length are much shortened    ■ Cooling capacity is lowered (pay attention to piping length)
- ×

\*The allowable minimum piping length is 5 m.

- Refer to the installation manual for details other than those mentioned in the left table such as additional refrigerant charge amount.
- Clean the existing piping if its length exceeds 30m.
- Clean the existing piping if existing piping length exceeds limit of chargeless piping length to perform pump-down refrigerant recovery.

## Night Quiet Operation Mode

### The automatic night quiet mode will initiate 8 hours after the peak temperature is reached in the daytime, and normal operation will resume 10 hours after that

\* Reducing noise will reduce capacity slightly.

Note : <sup>1</sup>Anechoic chamber conversion value, measured according to JIS parameters and criteria.  
During operation these values are somewhat higher owing to ambient conditions.  
<sup>2</sup>Value when cooling. Value will differ when heating.

Cooling only	Sound pressure level <sup>1</sup> (dB(A))	
	Rated <sup>2</sup>	Night Quiet Mode
RZF50-71C	48	44
RZF100C	49	45
RZF125C	52	45
RZF140C	54	45
RZA71B	48	45
RZA100B	51	48

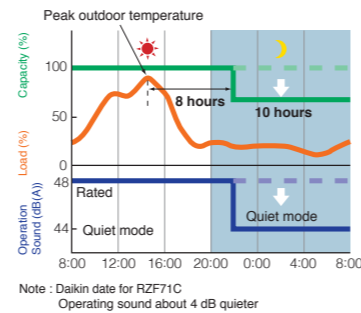

## Demand Control Function

### By setting limits that restrict power consumption, you can cut electricity bills (RZF100-140CVM, 71-140CYM, RZA71/100B)

Maximum power use is maintained within a set level of system capacity. This enables effective demand control while maintaining comfort. Maximum power consumption can be set at 40, 60, 70, 80, or 100%.

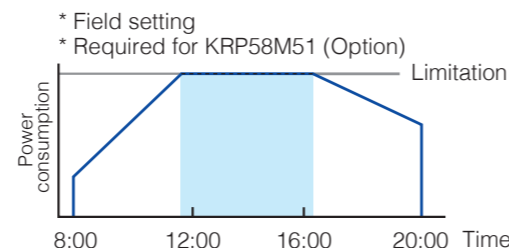

# Technology for energy efficiency

## The high efficiency compressor to achieve a high COP

### 1 Compressor equipped with reluctance DC motor

Daikin DC Inverter models are equipped with the reluctance DC motor for compressor. The reluctance DC motor uses 2 different types of torque, neodymium magnet\*1 and reluctance torque\*2. This motor can save energy because it generates more power with a smaller electric power than an AC or previous DC motor.

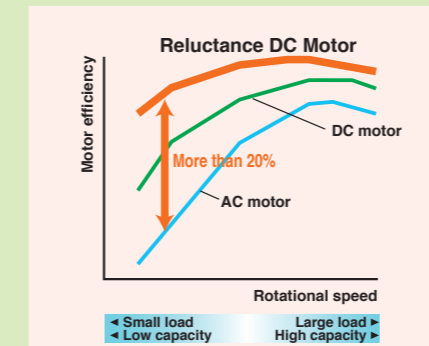

Note: Data are based on studies conducted under controlled conditions at a Daikin laboratory.



- \*1. A neodymium magnet is approximately 10 times stronger than a standard ferrite magnet.
- \*2. The torque created by the change in power between the iron and magnet parts.

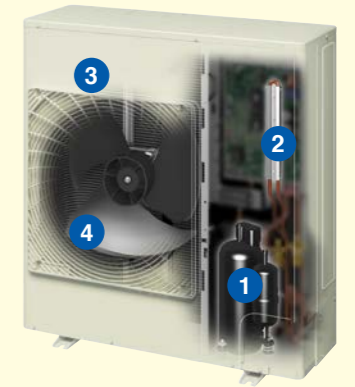

### Swing compressor

High efficiency during partial load operation.

Energy savings is realised, eliminating the friction and the leakage of refrigerant gas.

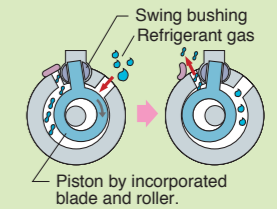

### 2 Refrigerant cooling (RZF100-140CVM, RZF71-140CYM, RZA71/100B)

Daikin's unique refrigerant cooling system exhibits high cooling capacity even during high outdoor temperatures.

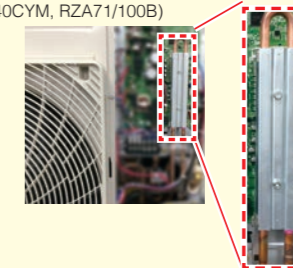

Refrigerant cooling helps protect the printed circuit board and maintains high cooling capacity even during high outdoor temperatures.

### 3 High condensing capacity by micro channel heat exchanger

RZF series only

#### Reduced wind resistance

The flattening of the heat exchanger tubes improves the flow of air and increases heat exchange efficiency.

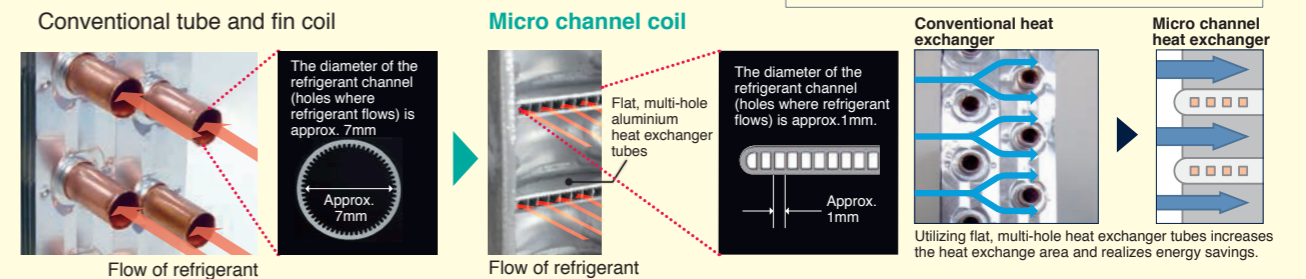

### 4 Fan

#### V-cut Propeller Fan (RZF50-100C)

Through use of a V-cut propeller fan that imitates the efficiency of the swan, a migratory bird, airflow becomes smooth and loss is reduced.



V-cut propeller fan  
Φ440 for RZF50-71CV2V  
Φ550 for RZF100CVM,  
RZF71-100CYM



Imitating the performance of the swan

# Easy-to-read LCD remote controller allows various system control configurations and can control multiple indoor units.

Remote controller options are shown on the page introducing each indoor unit model.

## Navigation Remote Controller (Wired LCD Remote Controller)

**NEW**

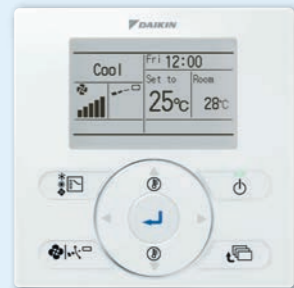

BRC1E63

This simple, modern designed remote controller with fresh white colour matches your interior design. Operation is much easier and smoother, just follow the indications on the navigation remote controller.

### Energy saving

#### Setpoint auto reset

- Even if the set temperature is changed, the new set temperature returns to the previous preset value after a preset duration of time.
- Period selectable from 30, 60, 90, or 120 min.

#### Restaurant example

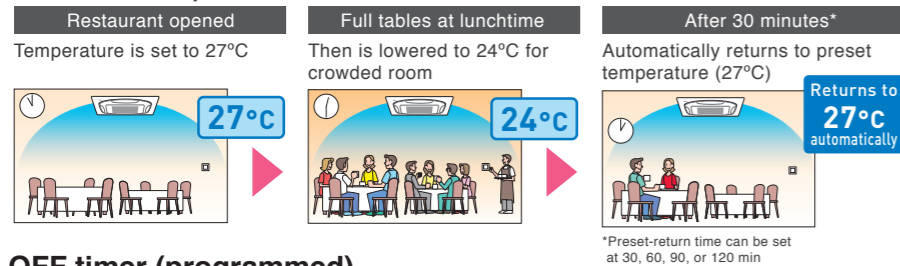

#### Setpoint range set

- Saves energy by limiting the min. and max. set temperature.
- Avoids excessive heating or cooling.
- This function is convenient if the remote controller is installed where anyone can change the settings.

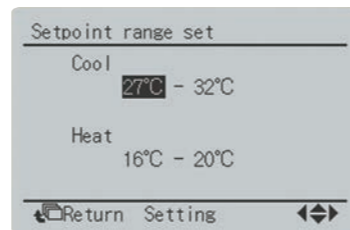

#### OFF timer (programmed)

- Sets and saves setting for an increment of time that automatically turns OFF air conditioner after a preset period of time for each time operation starts.
- Period can be preset from 30 to 180 minutes in 10-minute increments.

### Convenience

#### **NEW** 5-step airflow control

- The number of airflow steps depends on the type of indoor unit.
- 5-step control applies to FCF and FHA series.

#### Energy consumption monitoring <sup>\*1,2,3,4</sup>

- Past power consumption for the current and previous days (2-hour intervals), week (1-day intervals), and year (1-month intervals) can be checked.

Note:  
<sup>\*1</sup>Availability of this function may vary according to model (limited to partial functionality)  
<sup>\*2</sup>Time setting is necessary.  
<sup>\*3</sup>This function cannot be used during group control.  
<sup>\*4</sup>This is a reference value for comparison and is not intended as a value for investigation purposes in the calculation of electricity bills or contract for electricity. Because it is a simple calculation of power consumption, there are cases when the calculated value differs with the measurement results of a wattmeter.

#### Setback (default: OFF)

- Maintains the room temperature in a specific range during unoccupied periods by temporarily starting an air conditioner that had been turned OFF.

#### Weekly schedule

- 5 actions per day can be scheduled for each day of the week.
- The holiday function will disable schedule timer for the days that have been set as holiday.
- 3 independent schedules can be set. (e.g. summer, winter, mid-season)

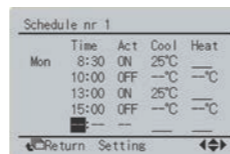

#### **NEW** Auto display off

- While operation is stopping, LCD display can be turned OFF. It will be displayed again if any button is pressed.
- Period can be preset from 10, 30, 60 minutes, and OFF. Initial setting is 30 minutes.

## Wireless LCD remote controller

**NEW**



BRC7M635F  
Signal receiver unit  
(For ceiling mounted cassette type)

- The wireless remote controller is supplied in a set with a signal receiver.
- Signal receiver unit of installed type is contained inside decoration panel or indoor unit.
- Shape of signal receiver unit differs according to the indoor unit.  
Note: The signal receiver unit shown in the photograph is for mounting inside the decoration panel of the ceiling mounted cassette type.

- NEW** ● Backlight LCD of new wireless remote controller



Pressing the backlight button helps operating in dark rooms.

### Wireless remote controller for each indoor unit type

	Cooling only	Heat pump
CEILING MOUNTED CASSETTE TYPE	<b>NEW</b> BRC7M635F (Fresh white) BRC7M635K (Black)	BRC7M634F (Fresh white) BRC7M634K (Black)
COMPACT MULTI FLOW TYPE	BRC7E531W	—
CEILING MOUNTED SLIM DUCT TYPE	BRC4C64	—
DUCT CONNECTION MIDDLE STATIC PRESSURE TYPE	BRC4C66	BRC4C65
CEILING SUSPENDED TYPE	<b>NEW</b> BRC7M56	BRC7M53
<b>NEW</b> FLOOR STANDING TYPE	BRC4C66	—

### Wired remote controller has built-in temperature-sensor

- Enables temperature sensing closer to target area for improved comfort. (When using a remote control from another room, temperature-sensor of the indoor unit air inlet must be selected.)

### Facilitates maintenance and repair

- All initial settings can be set from the remote controller. After interior construction is complete, ceiling mounted cassette type can be remotely set without having to use a stepladder to access for manual setting.  
Setting contents: High ceiling use, air direction, filter type, address for centralised control (group control address is set automatically).

- Remote controller is equipped with model name and failure display functions. This facilitates service in the unlikely event of a malfunction.

\*Model name display function applies to BRC1E63 only. (FFF series shows model code.)

### SkyAir shares common control with Heat Reclaim Ventilator and the other Daikin air-conditioning units, thus simplifying interlocking operations.

- Easily adaptable to large-scale, high-function, centralised remote control systems.  
Installing and connecting control wiring between SkyAir and other Daikin air-conditioning equipment is easy.

### LCD panel shows operating status in letters, numbers, and motion.

<b>Airflow / swing display</b>	Displays auto-swing operating status and setting position of air discharge angle.
<b>Preset temperature / operation mode display</b>	Displays preset room temperature and operating status (fan, dry, cool).
<b>Programming time display</b>	Operation start and stop time can be set for individual timers up to 72 hours. The LCD also shows when it is time to clean the filter, when changeover is under centralised control, and ventilation/cleaning.
<b>Self-diagnosis function</b>	Monitors operating status within the system covering 40 items, and displays a message to indicate as soon as a malfunction occurs.



System variation to control multiple indoor units

	Control pattern	Wired remote controller	Wireless remote controller
<b>Control by 1 remote controller</b>	(Basic system)	<ul style="list-style-type: none"> <li>● Non-polar, double-core (max. wiring length 500 m)</li> </ul>	<ul style="list-style-type: none"> <li>● Signal receiver unit installed on indoor unit</li> </ul>
<b>Control by 2 remote controllers</b>	For control from 2 locations such as in room and control room, exits, etc.	<ul style="list-style-type: none"> <li>● Connects 2 wired remote controllers (See note 1)</li> </ul>	<ul style="list-style-type: none"> <li>● Control by 1 wireless remote controller and 1 wired remote controller (See note 2)</li> <li>● Signal receiver unit installed on indoor unit</li> </ul>
<b>Group control</b>	For simultaneous control of up to 16 indoor units.	<ul style="list-style-type: none"> <li>● Automatic address setting function</li> </ul>	<ul style="list-style-type: none"> <li>● Automatic address setting function</li> <li>● Signal receiver unit installed on 1 indoor unit</li> </ul>
<b>Control by external command</b>	Operation and monitoring is carried out using the contact signal from the operation control box in the monitoring room.	<ul style="list-style-type: none"> <li>(Command from outside)</li> <li>● Optional wiring adaptor for electrical appendices is necessary</li> </ul>	<ul style="list-style-type: none"> <li>(Command from outside)</li> <li>● Optional wiring adaptor for electrical appendices is necessary</li> </ul>
<b>Centralised remote control</b>	Centralised control of up to 64 indoor groups from remote location up to 1 km away.	<ul style="list-style-type: none"> <li>Central remote controller (option)</li> <li>● Interface adaptor for SkyAir series (option) is required (See note 3)</li> </ul>	<ul style="list-style-type: none"> <li>Central remote controller (option)</li> <li>● Interface adaptor for SkyAir series (option) is required (See note 3)</li> </ul>
<b>Interlock control with Heat Reclaim Ventilator</b>	Link by remote controller group control.	<ul style="list-style-type: none"> <li>Heat Reclaim Ventilator</li> <li>● Can be operated simultaneously or independently by remote controller (set by ventilation mode)</li> </ul>	<ul style="list-style-type: none"> <li>Heat Reclaim Ventilator</li> <li>● Can be operated simultaneously by remote controller</li> </ul>
	Zone link control by centralised control.	<ul style="list-style-type: none"> <li>Central remote controller (option)</li> <li>Heat Reclaim Ventilator</li> <li>● Heat Reclaim Ventilator for indoor units within a zone is operated by interlocking. Can also be operated independently by remote controller.</li> </ul>	<ul style="list-style-type: none"> <li>Central remote controller (option)</li> <li>Heat Reclaim Ventilator</li> <li>● Heat Reclaim Ventilator for indoor units within a zone is operated by interlocking.</li> </ul>

Note: <sup>1</sup>BRC1E62 can connect to BRC1E62 only. BRC1E63 can connect BRC1E63 only. <sup>2</sup>When a wireless remote controller is used, it is not possible to use 2 wireless remote controllers. Combination of BRC1E63 (main) and BRC7M (sub) is available. <sup>3</sup>Compact multi flow cassette type (FFF) requires interface adaptor for SkyAir series. Slim duct type (FDF) cannot connect to centralised control because it cannot use interface adaptor.

Easily adaptable to large-scale, high-function, centralised remote control system.

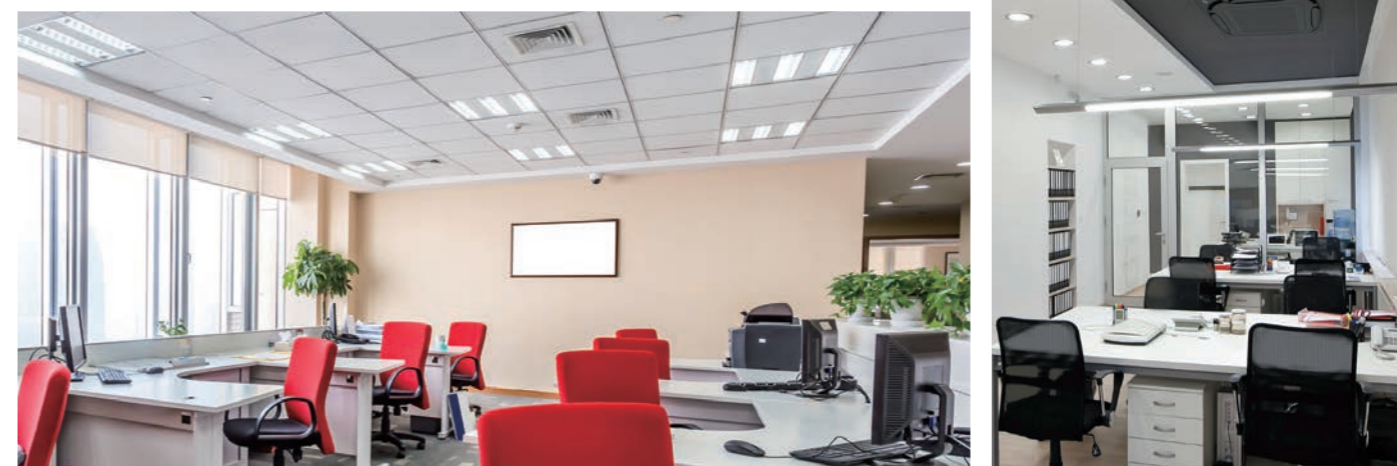
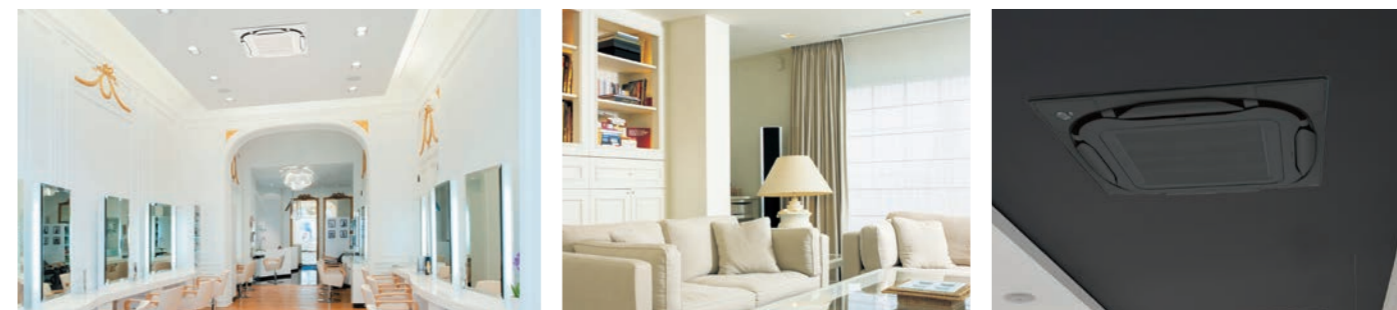

<p><b>Central remote controller</b> DCS302CA61 (Option)</p> <p>Centralised control, with setting as simple as it is with a standard remote controller, of up to 64 groups (1,024 indoor units) is possible.</p>	<p><b>Unified on/off controller</b> DCS301BA61 (Option)</p> <p>Centralised control of on/off by group or all at once for up to 256 indoor units.</p>	<p><b>Schedule timer</b> DST301BA61 (Option)</p> <p>Unified control of weekly schedule for up to 1,024 indoor units. Schedule timer sets on/off time in 1 minute units to be executed twice a day for a week at a time.</p>	<p><b>Intelligent Controller</b> DCS601C51 (Option)</p> <p>With its high functionality, the full colour "all-in-one" graphic controller facilitates management of SkyAir System in a variety of ways.</p>
<p><b>Interface adaptor for SkyAir series</b> DTA112BA51 (Option)</p> <p>Enables centralised control via connection to a high-speed, DIII-NET communication system, adopted for the Daikin VRF system.</p> <p>Necessary for interface adaptor for SkyAir series with the central remote control units shown at above.</p>			
<p>● The interface adaptor for SkyAir series is required for Compact multi flow cassette type (FFF). Slim duct type (FDF) cannot connect to centralised control because it cannot use interface adaptor.</p>			

Whatever your space, give it the comfort it deserves





# Functions overview

Cooling only

		CEILING MOUNTED CASSETTE TYPE (Round Flow)		COMPACT MULTI FLOW CEILING MOUNTED CASSETTE TYPE	
		 FCF50-140CVM		 FFF50/60BV1	
Indoor unit		RZF50-71CV2V, 100-140CVM RZF71-140CYM		RZF50/60CV2V	
Outdoor unit		RZF50-71CV2V, 100-140CVM RZF71-140CYM		RZF50/60CV2V	
Remote controller		BRC1E63		BRC1E63	
Wired		---		---	
Wireless		BRC7M635F (K)		BRC7E531W	
Energy Saving	1	Energy consumption monitoring *1	●		
	2	Sensing sensor stop mode *1	● Sensing panel		
	3	Sensing sensor low mode *1, 2	● Sensing panel		
	4	Auto display OFF *1	●		
	5	Setpoint auto reset *1	●	●	
	6	Setpoint range set *1	●	●	
	7	OFF timer (programmed) *1	●	●	
	8	Weekly schedule timer *1	●	●	
	9	ON/OFF timer		●	●
Comfort	10	Circulation airflow *1	●		
	11	Setback *1	●	●	
	12	Quick start *1	●	●	
	13	Individual airflow control *1	●		
	14	Infrared presence sensor		● Sensing panel	
	15	Infrared floor sensor		● Sensing panel	
	16	Auto airflow function *1	● Sensing panel		
	17	Auto swing	●	●	●
	18	Swing pattern selection	●	●	●
	19	Draft prevention function (heating)			
Cleanliness	20	Switchable fan speed	● 5 step	● 5 step	● 2 step
	21	Auto airflow rate	●	●	
	22	High fan speed mode			
	23	Two selectable temperature-sensors *1	●	●	
	24	High ceiling application	● 3.5m / 4.2m		
	25	Hot start			
	26	Year-round cooling applicable			
	27	Night quiet operation *3	●	●	
Work & Servicing	28	Anti-bacterial air filter	●		●
	29	Mould-proof air filter			
	30	Silver ion anti-bacterial drain pan	●		
	31	Mould-proof drain pan			●
Control	32	Auto grille panel	●		
	33	Drain pump mechanism	●		●
	34	Pre-charged for up to 30 m *3	●		●
	35	Long-life filter	●		●
	36	Filter sign	●	●	●
	37	Low gas pressure detection *3	●		●
	38	Emergency operation	●		●
	39	Self-diagnosis function	●	●	●
Options	40	Service contact display *1	●		●
	41	Auto-restart	●		●
	42	Auto-cooling / heating change-over			
	43	Control by 2 remote controllers	●	● *7	●
	44	Group control by 1 remote controller	●	●	●
	45	External equipment interlock *4		● Sensing panel	
	46	External signal forced OFF and ON/OFF operation	●		
	47	External command control *5	●		●
	48	Central remote control	●		● *6
	49	Interlock control with Heat Reclaim Ventilator	●		●
	50	DIII-NET communication standard	●		● *6
	51	High-efficiency filter	●		
	52	Ultra long-life filter	●		
	53	Fresh air intake kit	●		●
	54	Overvoltage PCB *3	●		●

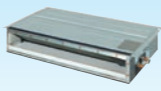
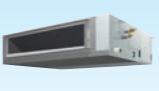
Note: \*1: Applicable when BRC1E63 is used \*2: Not applicable when group control \*3: For outdoor units  
 \*4: Adaptor for Wiring (and installation box) is necessary \*5: Wiring adaptor for electrical appendices (and installation box) is necessary  
 \*6: Option is required \*7: It is not possible to use 2 wireless remote controllers. Combination of BRC1E63 (main) and BRC7M (sub) is available.

		CEILING MOUNTED SLIM DUCT TYPE		DUCT CONNECTION MIDDLE STATIC PRESSURE TYPE		CEILING SUSPENDED TYPE		FLOOR STANDING TYPE	
		 FDF50/60BV1		 FBA50-140BVMA		 FHA50-100BVMV FHA125/140BVMA		 FVA50-140AMVM	
Indoor unit		RZF50/60CV2V		RZF50-71CV2V, 100-140CVM RZF71-140CYM		RZF50-71CV2V, 100-140CVM RZF71-140CYM		RZF50-71CV2V, 100-140CVM RZF71-140CYM	
Outdoor unit		RZF50/60CV2V		RZF50-71CV2V, 100-140CVM RZF71-140CYM		RZF50-71CV2V, 100-140CVM RZF71-140CYM		RZF50-71CV2V, 100-140CVM RZF71-140CYM	
Remote controller		BRC1E63		BRC1E63		BRC1E63		BRC1E63	
Wired		---		---		---		---	
Wireless		BRC4C64		BRC4C66		BRC7M56		BRC4C66	
Energy Saving	1								
	2								
	3								
	4	●		●		●		●	
	5	●		●		●		●	
	6	●		●		●		●	
	7	●		●		●		●	
	8	●		●		●		●	
	9		●		●		●		●
Comfort	10								
	11	●		●		●		●	
	12	●		●		●		●	
	13								
	14								
	15								
	16								
	17					●	●	●	●
	18								
	19								
Cleanliness	20	● 2 step	● 2 step	● 3 step	● 3 step	● 5 step	● 5 step	● 3 step	● 3 step
	21			●		●		●	
	22							● *8	
	23	●		●		●		●	
	24					● 3.5m / 4.3m			
	25								
	26								
	27	●		●		●		●	
Work & Servicing	28			● *6		●		●	
	29	●							
	30			●					
	31								
Control	32								
	33			●		● *6		●	
	34	●		●		●		●	
	35			● *6		●		●	
	36	●	●	●	●	●	●	●	●
	37	●		●		●		●	
	38	●		●		●		●	
	39	●	●	●	●	●	●	●	●
	40	●		●		●		●	
	41	●		●		●		●	
	42								
	43	●		●		●	● *7	●	
	44	●	●	●	●	●	●	●	●
	45								
	46			●		●		●	
	47			●		●		●	
	48			●		●		●	
	49	●		●		●		●	
50			●		●		●		
Options	51			●					
	52								
	53					●			
	54	●		●		●		●	

\*4: Adaptor for Wiring (and installation box) is necessary \*5: Wiring adaptor for electrical appendices (and installation box) is necessary  
 \*8: Applicable for FVA50-100

# Functions overview

Heat pump

		Indoor unit		CEILING MOUNTED CASSETTE TYPE (Round Flow)	
		Outdoor unit		RZA71/100BV2V	
		Remote controller	Wired Wireless	BRC1E63	BRC7M634F (K)
Energy Saving	1	Energy consumption monitoring *1		●	
	2	Sensing sensor stop mode *1		● Sensing panel	
	3	Sensing sensor low mode *1, 2		● Sensing panel	
	4	Auto display OFF *1		●	
	5	Setpoint auto reset *1		●	
	6	Setpoint range set *1		●	
	7	OFF timer (programmed) *1		●	
	8	Weekly schedule timer *1		●	
	9	ON/OFF timer			●
Comfort	10	Circulation airflow *1		●	
	11	Setback *1		●	
	12	Quick start *1		●	
	13	Individual airflow control *1		●	
	14	Infrared presence sensor			● Sensing panel
	15	Infrared floor sensor			● Sensing panel
	16	Auto airflow function *1		● Sensing panel	
	17	Auto swing		●	●
	18	Swing pattern selection		●	
	19	Draft prevention function (heating)		●	●
	20	Switchable fan speed		● 5 step	● 5 step
	21	Auto airflow rate		●	●
	22	High fan speed mode			
	23	Two selectable temperature-sensors *1		●	
	24	High ceiling application		● 3.5m / 4.2m	
	25	Hot start			●
	26	Year-round cooling applicable			●
27	Night quiet operation *3		●		
Cleanliness	28	Anti-bacterial air filter			●
	29	Mould-proof air filter			
	30	Silver ion anti-bacterial drain pan			●
	31	Mould-proof drain pan			
Work & Servicing	32	Auto grille panel			●
	33	Drain pump mechanism			●
	34	Pre-charged for up to 30 m *3			●
	35	Long-life filter			●
	36	Filter sign		●	●
	37	Low gas pressure detection *3			●
	38	Emergency operation			●
	39	Self-diagnosis function		●	●
	40	Service contact display *1		●	
	Control	41	Auto-restart		
42		Auto-cooling / heating change-over		●	●
43		Control by 2 remote controllers		●	● *7
44		Group control by 1 remote controller		●	●
45		External equipment interlock *4			● Sensing panel
46		External signal forced OFF and ON/OFF operation			●
47		External command control *5			●
48		Central remote control			●
49		Interlock control with Heat Reclaim Ventilator			●
50		DIII-NET communication standard			●
Options	51	High-efficiency filter			●
	52	Ultra long-life filter			●
	53	Fresh air intake kit			●
	54	Overvoltage PCB *3			

		DUCT CONNECTION MIDDLE STATIC PRESSURE TYPE		CEILING SUSPENDED TYPE	
		FBA71/100BVMA		FHA71/100BVMV	
		RZA71/100BV2V		RZA71/100BV2V	
		Remote controller	Wired Wireless	BRC1E63	BRC7M53
Energy Saving	1				
	2				
	3				
	4	●		●	
	5	●		●	
	6	●		●	
	7	●		●	
	8	●		●	
	9		●		●
Comfort	10				
	11	●		●	
	12	●		●	
	13				
	14				
	15				
	16				
	17			●	●
	18				
	19				●
	20	● 3 step	● 3 step	● 5 step	● 5 step
	21	●		●	●
	22				
	23	●		●	
	24			● 3.5m / 4.3m	
	25		●		●
	26		●		●
27	●		●		
Cleanliness	28		● *6		●
	29				
	30		●		
	31				
Work & Servicing	32				
	33		●		● *6
	34		●		●
	35		● *6		●
	36	●	●	●	●
	37		●		●
	38		●		●
	39	●	●	●	●
	40	●		●	●
	Control	41		●	
42		●	●	●	●
43		●		●	● *7
44		●	●	●	●
45					
46			●		●
47			●		●
48			●		●
49			●		●
50			●		●
Options	51		●		
	52				
	53				●
	54				

Note:

- \*1: Applicable when BRC1E63 is used
- \*2: Not applicable when group control
- \*3: For outdoor units
- \*4: Adaptor for Wiring (and installation box) is necessary
- \*5: Wiring adaptor for electrical appendices (and installation box) is necessary
- \*6: Option is required
- \*7: It is not possible to use 2 wireless remote controllers  
Combination of BRC1E63 (main) and BRC7M (sub) is available

# Abundance of functions that provide comfortable air-conditioning in stores and offices

Note: Some features are only available on selected models. See overview pages for full list of features applicable to each unit.

## Energy Saving

- 1. Energy consumption monitoring**  
Past power consumption is displayed for the current and previous days as well as in weekly and yearly intervals.
- 2. Sensing sensor stop mode**  
When the room is unoccupied, the system stops automatically.
- 3. Sensing sensor low mode**  
When the room is unoccupied, the set temperature is shifted automatically.
- 4. Auto display OFF**  
While operation is stopping, the LCD display can be turned off. It can be displayed again when any button is pressed.
- 5. Setpoint auto reset**  
Even if the set temperature is changed, the new set temperature returns to the previous preset value after a preset duration of time.
- 6. Setpoint range set**  
Saves energy by limiting the minimum and maximum set temperatures. Avoids excessive heating and cooling.
- 7. OFF timer (programmed)**  
Sets and saves setting for an increment of time that automatically turns off air conditioner after a preset period of time for each time operation starts.
- 8. Weekly schedule timer**  
Up to five operation ON/OFF settings can be programmed per day for each day of the week. Not only can the time be set for the operation ON setting, but also the temperature.
- 9. ON/OFF timer**  
Operation starts when the preset time of the ON timer elapses and stops when the preset time of the OFF timer elapses.

## Comfort

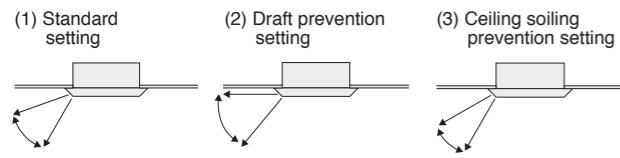
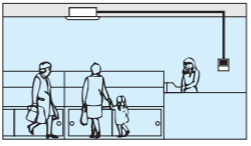
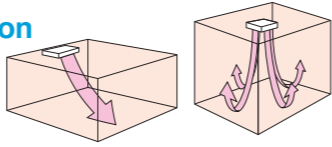
- 10. Circulation airflow**  
At the start of operation, airflow changes repeatedly between horizontal flow and downward flow (swing during cool operation), and air is sent throughout the room to eliminate uneven temperatures.
- 11. Setback**  
Maintains the room temperature in a specific range during unoccupied periods by temporarily starting an air conditioner that had been turned OFF.
- 12. Quick start**  
At operation start, capacity priority operation is possible.
- 13. Individual airflow control**  
Airflow direction can be individually adjusted for each air discharge outlet to deliver optimal air distribution.
- 14. Infrared presence sensor**  
The sensor detects the presence of people in each of the 4 areas.
- 15. Infrared floor sensor**  
The sensor detects the floor temperature and automatically adjusts operation of the indoor unit to reduce the temperature difference between the ceiling and the floor.
- 16. Auto airflow function**  
When this function is set, airflow direction can be directed toward or away from people when human presence is detected.
- 17. Auto swing**  
Delivers comfortable air-conditioning to all areas, near to and far from the air-conditioner.  
■ The air flow direction can be fixed at your desired angle by the remote controller.
- 18. Swing pattern selection**  
You can freely set air discharge settings by remote controller.  

- 19. Draft prevention function (heating)**  
To prevent cold air drafts, automatically adjusts airflow to near horizontal position when heating initially starts or when the thermo off.
- 20. Switchable fan speed**  
High setting provides maximum reach while low setting minimises drafts.
- 21. Auto airflow rate**  
Airflow rate is automatically controlled in accordance with the difference between room temperature and set temperature.
- 22. High fan speed mode**  
You can increase fan speed approximately 10% higher than the "high" setting.
- 23. Two selectable temperature-sensors**  
Temperature-sensors are included in the indoor unit and optional wired remote controller. Temperature sensing closer to target area is possible to further increase the comfort level.  
● Use the temperature-sensor in the indoor unit when controlling air conditioning from another room.  
Note: Wireless remote controllers have no temperature-sensor.  

- 24. High ceiling application**  
Delivers air-conditioning comfort all the way down to the floor in air-conditioning zones with high ceilings.  
Note: When units are installed on high ceilings, depending on the model, various restrictions concerning maximum height, air discharge direction, and choice of options may apply.  

- 25. Hot start**  
Cold air flow is avoided when heating operation starts or when switching to heat after defrosting.
- 26. Year-round cooling applicable**  
Efficient cooling even in winter when the indoor temperatures are higher than those outside, such as in underground public spaces or offices with many computers.
- 27. Night quiet operation**  
The Automatic night quiet mode will initiate 8 hours after the peak temperature is reached in the daytime, and normal operation will resume 10 hours after that.

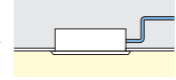
## Cleanliness

- 28. Anti-bacterial air filter**  
The air filter has an anti-bacterial treatment to help prevent the growth of bacteria and mould on it.
- 29. Mould-proof air filter**  
Sanitary filter has mould-resistant treatment.
- 30. Silver ion anti-bacterial drain pan**  
A built-in antibacterial treatment that uses silver ion in the drain pan prevents the growth of slime, bacteria, and mould that cause odours and clogging.
- 31. Mould-proof drain pan**  
Mould-proof drain pan prevents growth of mould in highly humid conditions.

## Work & Servicing

- 32. Auto grille panel**  
Grille and air filter cleaning can be performed without need for a stepladder by lowering the grille.
- 33. Drain pump mechanism**  
Steeper gradient realises more efficient condensate drainage. High-lift is especially useful for long lengths of drain piping.  

- 34. Pre-charged for up to 30 m**  
If refrigerant piping length does not exceed 30 m, there is no need for on-site gas charging.
- 35. Long-life filter**  
Maintenance is not required for one year\*. The filter is washable and can be reused.  
\*For dust concentration of 0.15 mg/m<sup>3</sup>
- 36. Filter sign**  
The filter sign warns you when it is time to clean the filter.  
\*When using a wired remote controller the sign is displayed in the LCD. When using a wireless remote controller the filter sign lamp illuminates on the signal receiver unit.
- 37. Low gas pressure detection**  
Insufficient gas charging is normally hard to detect. During test run after installation and regular inspection, the refrigerant level is monitored by a microprocessor to maintain proper gas pressure. Reliability is assured and maintenance and inspection can be carried out more quickly.
- 38. Emergency operation**  
Even if there is a malfunction elsewhere in the system, the fan or compressor can still be operated. (depending on the malfunction)
- 39. Self-diagnosis function**  
The operating parameters of indoor and outdoor units, and sensor data at critical locations throughout the system, are constantly monitored using a microcomputer. To facilitate quick response in the event of a malfunction, a message appears on the LCD of the remote controller and an LED on the unit illuminates.
- 40. Service contact display**  
When installing the unit, registration of the service contact is available to the wired remote controller.

## Control

- 41. Auto-restart**  
If there is a power outage while the equipment is operating, operations will restart in the same mode as before the power cut when electricity is restored.
- 42. Auto-cooling / heating change-over**  
Detects difference in preset temperature and actual room temperature and automatically switches to cooling or heating accordingly.
- 43. Control by 2 remote controllers**  
Using 2 remote controllers you can operate the equipment locally or from a remote location.  
\*When a wireless remote controller is used, it is not possible to use 2 wireless remote controllers.  
Combination of BRC1E63 (main) and BRC7M (sub) is available.
- 44. Group control by 1 remote controller**  
You can turn up to 16 indoor units ON/OFF with a single remote controller. (When using connected indoor units, the settings must all be the same and on/off will be simultaneous.)
- 45. External equipment interlock**  
Human presence is detected by the built-in infrared presence sensor in the sensing panel, and the presence detection signal can be output and interlocked with external equipment. Power conservation is possible though the interlock of external equipment, such as lighting, with the infrared presence sensor.  
\*Adaptor for Wiring (and installation box) is necessary.
- 46. External signal forced OFF and ON/OFF operation**  
The air conditioner can be interlocked with the keycard system and turned ON/OFF by locking and unlocking the room.  
The air conditioner can be also be turned OFF by the interlock with the ventilation and lighting OFF signal.  
\*Field setting with remote controller.
- 47. External command control**  
Operation and monitoring is carried out using the contact signal from the operation control box in the building monitoring room.  
\*Wiring adaptor for electrical appendices (and installation box) is necessary.
- 48. Central remote control**  
Optional central remote controller enables centralised control of up to 1024 indoor units (64 groups) from up to 1 km away.
- 49. Interlock control with Heat Reclaim Ventilator**  
Enables interlocking control with external equipment such as Heat Reclaim Ventilator.
- 50. DIII-NET communication standard**  
Connection to a centralised control system is available without need for an optional adaptor.

## Options

- 51. High-efficiency filter**  
Two types are available: 65% and 90% colorimetry.
- 52. Ultra long-life filter**  
Requires no maintenance for about 4 years\* (10,000h) in stores and offices.  
\*For dust concentration of 0.15 mg/m<sup>3</sup>
- 53. Fresh air intake kit**  
You can provide air-conditioning with fresh air from outside. Convenient for places where a ventilation fan cannot be installed.
- 54. Overvoltage PCB**  
Optional circuit eliminates the need for a stabiliser and offer additional protection for devices in the outdoor unit, such as its fan motor and compressor.

# SPECIFICATIONS



## CEILING MOUNTED CASSETTE TYPE <Round Flow> (1 Phase) Cooling only

Model Name	Indoor unit		50	60	71	100	125	140	
	Outdoor unit		FCF50CVM	FCF60CVM	FCF71CVM	FCF100CVM	FCF125CVM	FCF140CVM	
Power supply	Outdoor unit		1 Phase, 220V, 50Hz				1 Phase, 220-240V, 50Hz		
Cooling Capacity <sup>1,2</sup> Rated (Min. - Max.)	kW		5.0 (2.3-5.6)	6.0 (2.6-6.3)	7.1 (3.2-8.0)	10.0 (5.0-11.2)	12.5 (5.7-14.0)	14.0 (6.2-15.5)	
		Btu/h	17,100 (7,800-19,100)	20,500 (8,900-21,500)	24,200 (10,900-27,300)	34,100 (17,100-38,200)	42,700 (19,500-47,800)	47,800 (21,200-52,900)	
Power consumption	Cooling	kW	1.14	1.53	1.93	2.97	4.18	5.47	
COP		W/W	4.39	3.92	3.68	3.37	2.99	2.56	
CSPF		Wh/Wh	6.60	6.31	6.17	5.50	5.15	5.00	
Indoor unit	Colour	Unit	Fresh white						
		Decoration panel	Fresh white						
	Airflow rate (H / HM / M / ML / L)	m³/min	23.0 / 21.0 / 18.5 / 16.0 / 13.5				34.5 / 31.0 / 27.5 / 24.0 / 20.0		
		cfm	812 / 741 / 653 / 565 / 477				1,218 / 1,094 / 971 / 847 / 706		
	Sound pressure level <sup>3</sup> (H / HM / M / ML / L)	dB(A)	37.0 / 34.5 / 32.0 / 29.5 / 27.5				45.0 / 41.5 / 38.0 / 35.0 / 32.5		
		mm	256×840×840						
	Dimensions (H×W×D)	Unit	256×840×840						
		Decoration panel	50×950×950						
	Machine weight	Unit	22				24		
		Decoration panel	5.5						
Certified Operation range	°CWB	14 to 25							
	Colour	Ivory white							
Outdoor unit	Coil	Type	Micro channel						
		Compressor	Hermetically sealed swing type						
	Motor output	kW	1.3				1.6		
		kg	1.2 (Charged for 30 m)				1.3 (Charged for 30 m)		
	Sound pressure level <sup>3</sup>	Cooling	48				49		
		Night quiet mode	44				45		
	Dimensions (H×W×D)	mm	595×845×300				695×930×350		
		kg	41				48		
	Certified Operation range	°CDB	21 to 46						
		Liquid (Flare)	mm	φ9.5					
Piping connections	Gas (Flare)	mm	φ15.9						
		Drain	Indoor unit	VP25 (I.D. φ25×O.D. φ32)				φ18.0 (Hole)	
	Outdoor unit	mm	φ26.0 (Hole)				φ26.0 (Hole)		
		Max. interunit piping length	m	50 (Equivalent length 70)					
Max. installation level difference	m	30							
Heat insulation		Both liquid and gas piping							



## CEILING MOUNTED CASSETTE TYPE <Round Flow> (3 Phase) Cooling only

Model Name	Indoor unit		71	100	125	140
	Outdoor unit		RZF71CYM	RZF100CYM	RZF125CYM	RZF140CYM
Power supply	Outdoor unit		3 Phase, 380-415V, 50Hz			
Cooling Capacity <sup>1,2</sup> Rated (Min. - Max.)	kW		7.1 (3.2-8.0)	10.0 (5.0-11.2)	12.5 (5.7-14.0)	14.0 (6.2-15.5)
		Btu/h	24,200 (10,900-27,300)	34,100 (17,100-38,200)	42,700 (19,500-47,800)	47,800 (21,200-52,900)
Power consumption	Cooling	kW	1.93	2.97	4.18	5.47
COP		W/W	3.68	3.37	2.99	2.56
CSPF		Wh/Wh	6.17	5.50	5.15	5.00
Indoor unit	Colour	Unit	Fresh white			
		Decoration panel	Fresh white			
	Airflow rate (H / HM / M / ML / L)	m³/min	23.0 / 21.0 / 18.5 / 16.0 / 13.5		34.5 / 31.0 / 27.5 / 24.0 / 20.0	
		cfm	812 / 741 / 653 / 565 / 477		1,218 / 1,094 / 971 / 847 / 706	
	Sound pressure level <sup>3</sup> (H / HM / M / ML / L)	dB(A)	37.0 / 34.5 / 32.0 / 29.5 / 27.5		45.0 / 41.5 / 38.0 / 35.0 / 32.5	
		mm	256×840×840			
	Dimensions (H×W×D)	Unit	256×840×840			
		Decoration panel	50×950×950			
	Machine weight	Unit	22		24	
		Decoration panel	5.5			
Certified Operation range	°CWB	14 to 25				
	Colour	Ivory white				
Outdoor unit	Coil	Type	Micro channel			
		Compressor	Hermetically sealed swing type			
	Motor output	kW	1.6			
		kg	1.3 (Charged for 30 m)			
	Sound pressure level <sup>3</sup>	Cooling	48		49	
		Night quiet mode	44		45	
	Dimensions (H×W×D)	mm	695×930×350		990×940×320	
		kg	48		64	
	Certified Operation range	°CDB	21 to 46			
		Liquid (Flare)	mm	φ9.5		
Piping connections	Gas (Flare)	mm	φ15.9			
		Drain	Indoor unit	VP25 (I.D. φ25×O.D. φ32)		
	Outdoor unit	mm	φ18.0 (Hole)		φ26.0 (Hole)	
		Max. interunit piping length	m	50 (Equivalent length 70)		
Max. installation level difference	m	30				
Heat insulation		Both liquid and gas piping				

Note:  
<sup>1</sup>Rated cooling capacities are based on the following conditions: Indoor temp., 27°CDB, 19°CWB; outdoor temp. 35°CDB, 24°CWB. Equiv. refrigeration piping, 7.5 m (horizontal).  
<sup>2</sup>Capacities are net, including a deduction for cooling for indoor fan motor heat.  
<sup>3</sup>The operation sound is measured in anechoic chamber. If it is measured under the actual installation conditions, it is normally over the set value due to environmental noise and sound reflection.



## COMPACT MULTI FLOW CEILING MOUNTED CASSETTE TYPE (1 Phase) Cooling only

Model Name	Indoor unit		50	60
	Outdoor unit		RZF50CV2V	RZF60CV2V
Power supply	Outdoor unit		1 Phase, 220V, 50Hz	
Cooling Capacity <sup>1,2</sup> Rated (Min. - Max.)	kW		5.0 (2.3-5.6)	6.0 (2.6-6.3)
		Btu/h	17,100 (7,800-19,100)	20,500 (8,900-21,500)
Power consumption	Cooling	kW	1.51	2.00
COP		W/W	3.31	3.00
CSPF		Wh/Wh	4.96	4.73
Indoor unit	Colour	Unit	White	
		Decoration panel	White	
	Airflow rate (H/L)	m³/min	15.0 / 10.0	
		cfm	530 / 353	
	Sound pressure level <sup>3</sup> (H/L)	dB(A)	41 / 32	
		mm	260(286)×575×575 (*Include control box)	
	Dimensions (H×W×D)	Unit	260(286)×575×575 (*Include control box)	
		Decoration panel	55×700×700	
	Machine weight	Unit	17.5	
		Decoration panel	2.7	
Certified Operation range	°CWB	14 to 25		
	Colour	Ivory white		
Outdoor unit	Coil	Type	Micro channel	
		Compressor	Hermetically sealed swing type	
	Motor output	kW	1.3	
		kg	1.2 (Charged for 30 m)	
	Sound pressure level <sup>3</sup>	Cooling	48	
		Night quiet mode	44	
	Dimensions (H×W×D)	mm	595×845×300	
		kg	41	
	Certified Operation range	°CDB	21 to 46	
		Liquid (Flare)	mm	φ9.5
Piping connections	Gas (Flare)	mm	φ15.9	
		Drain	Indoor unit	VP20 (I.D. φ20×O.D. φ26)
	Outdoor unit	mm	φ26.0 (Hole)	
		Max. interunit piping length	m	50 (Equivalent length 70)
Max. installation level difference	m	30		
Heat insulation		Both liquid and gas piping		

Note:  
<sup>1</sup>Rated cooling capacities are based on the following conditions: Indoor temp., 27°CDB, 19°CWB; outdoor temp. 35°CDB, 24°CWB. Equiv. refrigeration piping, 7.5 m (horizontal).  
<sup>2</sup>Capacities are net, including a deduction for cooling for indoor fan motor heat.  
<sup>3</sup>The operation sound is measured in anechoic chamber. If it is measured under the actual installation conditions, it is normally over the set value due to environmental noise and sound reflection.

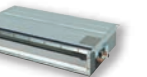

## CEILING MOUNTED SLIM DUCT TYPE (1 Phase) Cooling only

Model Name	Indoor unit		50	60
	Outdoor unit		RZF50CV2V	RZF60CV2V
Power supply	Outdoor unit		1 Phase, 220V, 50Hz	
Cooling Capacity <sup>1,2</sup> Rated (Min. - Max.)	kW		5.0 (2.3-5.6)	6.0 (2.6-6.3)
		Btu/h	17,100 (7,800-19,100)	20,500 (8,900-21,500)
Power consumption	Cooling	kW	1.51	1.98
COP		W/W	3.31	3.03
CSPF		Wh/Wh	4.98	4.78
Indoor unit	Colour	Unit	White	
		Decoration panel	White	
	Airflow rate (H/L)	m³/min	16.0 / 13.5	
		cfm	565 / 477	
	Sound pressure level <sup>3</sup> (H/L)	dB(A)	38 / 34	
		mm	200×1100×620	
	Dimensions (H×W×D)	Unit	200×1100×620	
		kg	30	
	Certified Operation range	°CWB	14 to 25	
		Colour	Ivory white	
Outdoor unit	Coil	Type	Micro channel	
		Compressor	Hermetically sealed swing type	
	Motor output	kW	1.3	
		kg	1.2 (Charged for 30 m)	
	Sound pressure level <sup>3</sup>	Cooling	48	
		Night quiet mode	44	
	Dimensions (H×W×D)	mm	595×845×300	
		kg	41	
	Certified Operation range	°CDB	21 to 46	
		Liquid (Flare)	mm	φ9.5
Piping connections	Gas (Flare)	mm	φ15.9	
		Drain	Indoor unit	VP20 (I.D. φ20×O.D. φ26)
	Outdoor unit	mm	φ26.0 (Hole)	
		Max. interunit piping length	m	50 (Equivalent length 70)
Max. installation level difference	m	30		
Heat insulation		Both liquid and gas piping		

Note:  
<sup>1</sup>Rated cooling capacities are based on the following conditions: Indoor temp., 27°CDB, 19°CWB; outdoor temp. 35°CDB, 24°CWB. Equiv. refrigeration piping, 7.5 m (horizontal).  
<sup>2</sup>Capacities are net, including a deduction for cooling for indoor fan motor heat.  
<sup>3</sup>The operation sound is measured in anechoic chamber. If it is measured under the actual installation conditions, it is normally over the set value due to environmental noise and sound reflection.





FLOOR STANDING TYPE (1 Phase) Cooling only

Model Name		50	60	71	100	125	140	
Indoor unit	Indoor unit	FVA50AMVM	FVA60AMVM	FVA71AMVM	FVA100AMVM	FVA125AMVM	FVA140AMVM	
	Outdoor unit	RZF50CV2V	RZF60CV2V	RZF71CV2V	RZF100CVM	RZF125CVM	RZF140CVM	
Power supply	Outdoor unit	1 Phase, 220V, 50Hz			1 Phase, 220-240V, 50Hz			
Cooling Capacity <sup>1,2</sup> Rated (Min. - Max.)	kW	5.0 (2.3-5.6)	6.0 (2.6-6.3)	7.1 (3.2-8.0)	10.0 (5.0-11.2)	12.5 (5.7-14.0)	14.0 (6.2-15.5)	
	Btu/h	17,100 (7,800-19,100)	20,500 (8,900-21,500)	24,200 (10,900-27,300)	34,100 (17,100-38,200)	42,700 (19,500-47,800)	47,800 (21,200-52,900)	
Power consumption	Cooling	1.23	1.79	2.51	3.48	4.48	5.71	
COP	W/W	4.07	3.35	2.83	2.87	2.79	2.45	
CSPF	Wh/Wh	6.03	4.86	4.46	4.19	4.67	4.18	
Indoor unit	Colour	Fresh white						
	Airflow rate (H / M / L)	18 / 16 / 14		28 / 25 / 22		30 / 28 / 26		
	Sound pressure level <sup>3</sup> (H / M / L)	635 / 565 / 494		988 / 883 / 777		1,059 / 988 / 918		
	Dimensions (H×W×D)	43 / 41 / 38		50 / 47 / 44		53 / 51 / 48		
	Machine weight	1,850×600×270		1,850×600×350		50		
	Certified Operation range	14 to 25						
	Outdoor unit	Colour	Ivory white					
Outdoor unit	Coil	Micro channel						
	Compressor	Hermetically sealed swing type						
	Motor output	1.30		1.60		2.40		
	Refrigerant charge (R32)	1.2 (Charged for 30 m)		1.3 (Charged for 30 m)		1.9 (Charged for 30 m)		
	Sound pressure level <sup>3</sup>	Cooling	48		49		52	
		Night quiet mode	44		45		54	
	Dimensions (H×W×D)	595×845×300		695×930×350		990×940×320		
	Machine weight	41		48		64		
	Certified Operation range	21 to 46						
	Piping connections	Liquid (Flare)	φ9.5					
Gas (Flare)		φ15.9						
Drain		Indoor unit		VP20 (I.D.φ20×O.D.φ26)		φ26.0 (Hole)		
Max. interunit piping length	50 (Equivalent length 70)							
Max. installation level difference	30							
Heat insulation	Both liquid and gas piping							

FLOOR STANDING TYPE (3 Phase) Cooling only

Model Name		71	100	125	140	
Indoor unit	Indoor unit	FVA71AMVM	FVA100AMVM	FVA125AMVM	FVA140AMVM	
	Outdoor unit	RZF71CYM	RZF100CYM	RZF125CYM	RZF140CYM	
Power supply	Outdoor unit	3 Phase, 380-415V, 50Hz				
Cooling Capacity <sup>1,2</sup> Rated (Min. - Max.)	kW	7.1 (3.2-8.0)	10.0 (5.0-11.2)	12.5 (5.7-14.0)	14.0 (6.2-15.5)	
	Btu/h	24,200 (10,900-27,300)	34,100 (17,100-38,200)	42,700 (19,500-47,800)	47,800 (21,200-52,900)	
Power consumption	Cooling	2.51	3.48	4.48	5.71	
COP	W/W	2.83	2.87	2.79	2.45	
CSPF	Wh/Wh	4.46	4.19	4.67	4.18	
Indoor unit	Colour	Fresh white				
	Airflow rate (H / M / L)	18 / 16 / 14		28 / 26 / 24		
	Sound pressure level <sup>3</sup> (H / M / L)	635 / 565 / 494		988 / 918 / 847		
	Dimensions (H×W×D)	43 / 41 / 38		50 / 47 / 44		
	Machine weight	1,850×600×270		1,850×600×350		
	Certified Operation range	14 to 25				
	Outdoor unit	Colour	Ivory white			
Outdoor unit	Coil	Micro channel				
	Compressor	Hermetically sealed swing type				
	Motor output	1.60		2.40		
	Refrigerant charge (R32)	1.3 (Charged for 30 m)		1.9 (Charged for 30 m)		
	Sound pressure level <sup>3</sup>	Cooling	48		49	
		Night quiet mode	44		45	
	Dimensions (H×W×D)	695×930×350		990×940×320		
	Machine weight	48		64		
	Certified Operation range	21 to 46				
	Piping connections	Liquid (Flare)	φ9.5			
Gas (Flare)		φ15.9				
Drain		Indoor unit		VP20 (I.D.φ20×O.D.φ26)		
Max. interunit piping length	50 (Equivalent length 70)					
Max. installation level difference	30					
Heat insulation	Both liquid and gas piping					

Note :  
<sup>1</sup>Rated cooling capacities are based on the following conditions: Indoor temp., 27°CDB, 19°CWB; outdoor temp. 35°CDB, 24°CWB. Equiv. refrigeration piping, 7.5 m (horizontal).  
<sup>2</sup>Capacities are net, including a deduction for cooling for indoor fan motor heat.  
<sup>3</sup>The operation sound is measured in anechoic chamber. If it is measured under the actual installation conditions, it is normally over the set value due to environmental noise and sound reflection.

CEILING MOUNTED CASSETTE TYPE <Round Flow> (1 Phase) Heat pump

Model Name		71	100	
Indoor unit	Indoor unit	FCF71CVM	FCF100CVM	
	Outdoor unit	RZA71BV2V	RZA100BV2V	
Power supply	Outdoor unit	1 Phase, 220V, 50Hz		
Cooling capacity <sup>1,2</sup> Rated (Min. - Max.)	kW	7.1 (3.2-8.0)	10.0 (5.0-11.2)	
	Btu/h	24,200 (10,900-27,300)	34,100 (17,100-38,200)	
Heating capacity <sup>1,2</sup> Rated (Min. - Max.)	kW	7.1 (3.2-8.0)	10.0 (5.0-11.2)	
	Btu/h	24,200 (10,900-27,300)	34,100 (17,100-38,200)	
Power consumption <sup>1,2</sup>	Cooling	1.92	2.63	
	Heating	1.58	2.38	
COP	Cooling	3.70	3.80	
	Heating	4.49	4.20	
CSPF	Cooling	5.75	5.41	
Indoor unit	Colour	Fresh white		
	Airflow rate (H / HM / M / ML / L)	23.0 / 21.0 / 18.5 / 16.0 / 13.5		
	Sound pressure level <sup>3</sup> (H / HM / M / ML / L)	812 / 741 / 653 / 565 / 477		
	Dimensions (H×W×D)	256×840×840		
	Machine weight	22		
	Certified Operation range	14 to 25		
	Outdoor unit	Colour	Ivory white	
Outdoor unit	Coil	Cross fin coil		
	Compressor	Hermetically sealed swing type		
	Motor output	2.4		
	Refrigerant charge (R32)	2.6 (Charged for 30 m)		
	Sound pressure level <sup>3</sup>	Cooling / Heating	48 / 50	
		Night quiet mode	45	
	Dimensions (H×W×D)	990×940×320		
	Machine weight	73		
	Certified Operation range	Cooling	-5 to 50	
		Heating	-15 to 15.5	
Piping connections	Liquid (Flare)	φ9.5		
	Gas (Flare)	φ15.9		
	Drain	Indoor unit		
Max. interunit piping length	50 (Equivalent length 70)			
Max. installation level difference	30			
Heat insulation	Both liquid and gas piping			

DUCT CONNECTION MIDDLE STATIC PRESSURE TYPE (1 Phase) Heat pump

Model Name		71	100	
Indoor unit	Indoor unit	FBA71BVMA	FBA100BVMA	
	Outdoor unit	RZA71BV2V	RZA100BV2V	
Power supply	Outdoor unit	1 Phase, 220V, 50Hz		
Cooling capacity <sup>1,2</sup> Rated (Min. - Max.)	kW	7.1 (3.2-8.0)	10.0 (5.0-11.2)	
	Btu/h	24,200 (10,900-27,300)	34,100 (17,100-38,200)	
Heating capacity <sup>1,2</sup> Rated (Min. - Max.)	kW	7.1 (3.2-8.0)	10.0 (5.0-11.2)	
	Btu/h	24,200 (10,900-27,300)	34,100 (17,100-38,200)	
Power consumption <sup>1,2</sup>	Cooling	2.22	2.82	
	Heating	2.22	3.55	
COP	Cooling	3.20	3.55	
	Heating	3.20	3.55	
CSPF	Cooling	5.69	5.36	
Indoor unit	Colour	Ivory white		
	Fan	Airflow rate (H/M/L)		
	Sound pressure level <sup>3</sup> (H/M/L)	m³/min	23.0 / 19.5 / 16.0	
		cfm	812 / 688 / 565	
	External static pressure <sup>4</sup>	Pa		
	Rated 50 (50-150)	38.0 / 35.0 / 33.0		
	Dimensions (H×W×D)	mm		
Machine weight	kg			
Certified Operation range	Cooling	14 to 25		
	Heating	15 to 27		
Outdoor unit	Colour	Ivory white		
	Coil	Cross fin coil		
	Compressor	Hermetically sealed swing type		
	Motor output	2.4		
	Refrigerant charge (R32)	2.6 (Charged for 30 m)		
	Sound pressure level <sup>3</sup>	Cooling / Heating	48 / 50	
		Night quiet mode	45	
Dimensions (H×W×D)	990×940×320			
Machine weight	73			
Certified Operation range	Cooling	-5 to 50		
	Heating	-15 to 15.5		
Piping connections	Liquid (Flare)	φ9.5		
	Gas (Flare)	φ15.9		
	Drain	Indoor unit		
Max. interunit piping length	50 (Equivalent length 70)			
Max. installation level difference	30			
Heat insulation	Both liquid and gas piping			



CEILING SUSPENDED TYPE (1 Phase) Heat pump

		71	100	
Model Name	Indoor unit	FHA71BVMV	FHA100BVMV	
	Outdoor unit	RZA71BV2V	RZA100BV2V	
Power supply	Outdoor unit	1 Phase, 220V, 50Hz		
Cooling capacity <sup>1,2</sup> Rated (Min. - Max.)	kW	7.1 (3.2-8.0)	10.0 (5.0-11.2)	
	Btu/h	24,200 (10,900-27,300)	34,100 (17,100-38,200)	
Heating capacity <sup>1,2</sup> Rated (Min. - Max.)	kW	7.1 (3.2-8.0)	10.0 (5.0-11.2)	
	Btu/h	24,200 (10,900-27,300)	34,100 (17,100-38,200)	
Power consumption <sup>1,2</sup>	Cooling	2.22	2.86	
	Heating	1.82	2.50	
COP	Cooling	3.20	3.50	
	Heating	3.90	4.00	
CSPF	Cooling	5.69	5.36	
Indoor unit	Colour	White		
	Airflow rate (H / HM / M / ML / L)	m <sup>3</sup> /min	20.5 / 18.8 / 17.0 / 15.5 / 14.0	28.0 / 26.0 / 24.0 / 22.0 / 20.0
		cfm	724 / 664 / 600 / 547 / 494	988 / 918 / 847 / 777 / 706
	Sound pressure level <sup>3</sup> (H / HM / M / ML / L)	dB(A)	38.0 / 37.0 / 36.0 / 35.0 / 34.0	42.0 / 40.0 / 38.0 / 36.0 / 34.0
	Dimensions (H×W×D)	mm	235×1270×690	235×1590×690
	Machine weight	kg	32	38
	Certified Operation range	Cooling	14 to 25	
		Heating	15 to 27	
	Outdoor unit	Colour	Ivory white	
		Coil	Type	Cross fin coil
Compressor		Type	Hermetically sealed swing type	
		Motor output	2.4	
Refrigerant charge (R32)		kg	2.6 (Charged for 30 m)	
Sound pressure level <sup>3</sup>		Cooling / Heating	dB(A)	48 / 50
		Night quiet mode	dB(A)	45
Dimensions (H×W×D)		mm	990×940×320	
Machine weight		kg	73	74
Certified Operation range		Cooling	°CDB -5 to 50	
	Heating	°CWB -15 to 15.5		
Piping connections	Liquid (Flare)	mm	φ9.5	
	Gas (Flare)	mm	φ15.9	
	Drain	Indoor unit	mm	VP25 (I.D. φ25×O.D. φ32)
Outdoor unit		mm	φ26.0 (Hole)	
Max. interunit piping length	m	50 (Equivalent length 70)		
Max. installation level difference	m	30		
Heat insulation		Both liquid and gas piping		

Note :  
<sup>1</sup>Rated cooling capacities are based on the following conditions: Indoor temp., 27°CDB, 19°CWB; outdoor temp. 35°CDB, 24°CWB. Equiv. refrigeration piping, 7.5 m (horizontal).  
<sup>2</sup>Rated heating capacities are based on the following conditions: Indoor temp., 20°CDB, 15°CWB; outdoor temp., 7°CDB, 6°CWB. Equiv. refrigeration piping, 7.5 m (horizontal).  
<sup>3</sup>Capacities are net, including a deduction for cooling for indoor fan motor heat.  
<sup>4</sup>The operation sound is measured in anechoic chamber. If it is measured under the actual installation conditions, it is normally over the set value due to environmental noise and sound reflection.  
<sup>5</sup>External static pressure is changeable in 11 stages by remote controller.  
<sup>6</sup>Air filter is not standard accessory, but please mount it in the duct system of the suction side. Select its dust collection efficiency(gravity method) 50% or more.

Indoor unit

CEILING MOUNTED CASSETTE TYPE <Round Flow>

Name of option	Remark	Kit name					
		FCF50CVM	FCF60CVM	FCF71CVM	FCF100CVM	FCF125CVM	FCF140CVM
1 Decoration panel	Standard panel with Sensing	Fresh white	BYCQ125EEF				
		Black	BYCQ125EEK				
	Standard panel	Fresh white	BYCQ125EAF				
		Black	BYCQ125EAK				
2 Sealing material of air discharge outlet <sup>4</sup>	Designer panel <sup>1</sup>	Fresh white	BYCQ125EAPF				
	Auto grille panel <sup>2,3</sup>	Fresh white	BYCQ125EASF				
3 Panel spacer		For usage of 3-, 4-way flow	KDBH551C160				
		For usage of 2-way flow	KDBH552C160				
4 Fresh air intake kit	Chamber type <sup>5,6</sup>	Without T-duct joint	KDDP55B160 (Components: KDDP55C160-1, KDDP55B160-2) <sup>8</sup>				
		With T-duct joint	KDDP55B160K (Components: KDDP55C160-1, KDDP55B160K2) <sup>8</sup>				
		Direct installation type <sup>7</sup>	KDDP55X160A				
5 High-efficiency filter unit <sup>9</sup> (Including filter chamber)	(Colorimetric method 65%)		KAFP556C80	KAFP556C160			
	(Colorimetric method 90%)		KAFP557C80	KAFP557C160			
6 Replacement high-efficiency filter <sup>9,10</sup>	(Colorimetric method 65%)		KAFP552B80	KAFP552B160			
	(Colorimetric method 90%)		KAFP553B80	KAFP553B160			
7 Filter chamber		KDDFP55C160					
8 Replacement long-life filter		KAFP551K160					
9 Replacement long-life filter (Auto grille panel)		KAFP551H160					
10 Ultra long-life filter unit (Including filter chamber) <sup>9</sup>		KAFP55C160					
11 Replacement ultra long-life filter <sup>9,10</sup>		KAFP55H160H					
12 Branch duct chamber <sup>4</sup>			KDJP55C80	KDJP55C160			
13 Insulation kit for high humidity <sup>9,11</sup>			KDTP55K80A	KDTP55K160A			
14 Remote controller	Wireless type	Cooling only	BRC7M635F (Fresh white) / BRC7M635K (Black)				
		Heat pump	BRC7M634F (Fresh white) / BRC7M634K (Black)				
15 Navigation remote controller	Wired type <sup>12</sup>	BRC1E63					
16 Central remote controller <sup>13</sup>		DCS302CA61					
17 Unified ON/OFF controller <sup>13</sup>		DCS301BA61					
18 Schedule timer <sup>13</sup>		DST301BA61					
19 Intelligent Touch Controller <sup>13</sup>		DCS601C51					
20 Adaptor for wiring <sup>14</sup>		KRP1C11A					
21 Wiring adaptor for electrical appendices <sup>14</sup>		KRP4AA53					
22 Installation box for adaptor PCB		KRP1H98A					
23 Remote sensor (for indoor temperature)		KRCS01-5B					

Note: <sup>1</sup>When installing designer panel, body height (ceiling required dimension) is 42 mm higher than standard panel. Designer panel cannot operate 2 and 3 way flow.  
<sup>2</sup>A dedicated remote controller (BRC16A2) for the auto grille panel is included for lowering and raising the suction grille.  
<sup>3</sup>When installing auto grille panel, body height (ceiling required dimension) is 55 mm higher than standard panel.  
<sup>4</sup>Circulation airflow is not available with this option.  
<sup>5</sup>When installing a fresh air intake kit (chamber type), two air outlet corners are closed.  
<sup>6</sup>It is recommended that the volume of outdoor air introduced through the kit is limited to 10% of the maximum airflow rate of the indoor unit. Introducing higher quantities will increase the operating sound and may also influence temperature sensing.  
<sup>7</sup>The volume of fresh air for direct installation type is approximately 1% of the indoor unit airflow.  
<sup>8</sup>The chamber type is recommended when more fresh air is necessary.  
<sup>9</sup>Please order using the names of both components instead of set name.  
<sup>10</sup>This option cannot be installed to designer panel and auto grille panel.  
<sup>11</sup>Filter chamber is required.  
<sup>12</sup>Please use in case temperature/humidity inside ceiling may get over 30°C, 80% RH.  
<sup>13</sup>Wiring for wired remote controller should be obtained locally.  
<sup>14</sup>The indoor unit is equipped standardly with the interface adaptor for SkyAir series. An option is unnecessary.  
<sup>15</sup>Installation box for adaptor PCB(KRP1H98A) is necessary.

Round flow type: List of optional parts required to achieve different flow patterns

For each flow pattern – all round, 4-way, 3-way, 2-way, branch duct connection – the compatibility of each independently installed option (shown in the column on the left) to accessory options (listed across the top of each table) is shown in the cells where the relevant row and column intersect. A circle (O) indicates compatibility, and a cross (X) indicates incompatibility. Any options not shown below are not suitable for independent or accessory installation.

All round flow • 4-way flow

Independently installable optional parts	Optional accessory parts	Designer panel	Auto grille panel	Panel spacer <sup>1</sup>	Fresh air intake kit (Chamber type) <sup>1,2</sup>	Fresh air intake kit (Direct installation type)	Insulation kit for high humidity	High-efficiency filter unit <sup>2</sup>	Ultra long-life filter unit <sup>2</sup>
		Panel/grille related	Designer panel		X	O	O	O	X
	Auto grille panel	X		O	O	O	X	X	X
	Panel spacer <sup>1</sup>	O	O		O	O	X	O	O
Auxiliary function related	Fresh air intake kit (Chamber type) <sup>1,2</sup>	O	O	O		X	O	O	O
	Fresh air intake kit (Direct installation type)	O	O	O	X		O	O	O
	Insulation kit for high humidity	X	X	X	X	O		X	X
Filter related	High-efficiency filter unit <sup>2</sup>	X	X	O	O	O	X		X
	Ultra long-life filter unit <sup>2</sup>	X	X	O	O	O	X		X

3-way flow • 2-way flow<sup>5</sup>

Independently installable optional parts	Optional accessory parts	Designer panel	Auto grille panel	Panel spacer <sup>1,3</sup>	Fresh air intake kit (Chamber type) <sup>1,2</sup>	Fresh air intake kit (Direct installation type)	Insulation kit for high humidity	High-efficiency filter unit <sup>2</sup>	Ultra long-life filter unit <sup>2</sup>
		Panel/grille related	Auto grille panel	X		△	O	O	X
	Panel spacer <sup>1,3</sup>	X	△		△	△	X	X	△
Auxiliary function related	Fresh air intake kit (Chamber type) <sup>1,2</sup>	X	O	△		X	X	X	O
	Fresh air intake kit (Direct installation type)	X	O	△	X		O	X	O
	Insulation kit for high humidity	X	X	X	X	O		X	X
Filter related	Ultra long-life filter unit <sup>2</sup>	X	X	△	O	O	X		X

Branch duct connection

Independently installable optional parts	Optional accessory parts	Designer panel	Auto grille panel	Panel spacer <sup>1</sup>	Fresh air intake kit (Chamber type) <sup>1,2</sup>	Fresh air intake kit (Direct installation type)	Insulation kit for high humidity	High-efficiency filter unit <sup>2</sup>	Ultra long-life filter unit <sup>2</sup>
		Branch duct chamber <sup>1</sup>	1-way branch / unit 3-way flow	O	O	O	O	O <sup>4</sup>	X
	2-way branch / unit 2-way flow	X	O	X	O	O <sup>4</sup>	X	X	O
	1-way branch / unit 2-way flow	X	O	X	O	O <sup>4</sup>	X	X	O

1. In some cases, depending on how the unit is embedded in the ceiling, use of branch ducts and fresh air intake kits may not be possible. Before starting installation work make sure to check whether or not joint installation is possible. In particular, ensure that the lower fixing position caused by the addition of panel spacers is acceptable.  
 When branch ducts are used, circulation airflow is not available.  
 2. When two different types of optional chambers are used together, a fresh air intake kit must be installed in the upper position.  
 3. It is not possible to use panel spacers in a 2-way flow installation. (△)  
 4. It is not possible to install a branch duct on the same side to which a fresh air intake kit (direct mount) is installed.  
 5. When 3-way or 2-way flow is selected, circulation airflow is not available.



Indoor unit



COMPACT MULTI FLOW CEILING MOUNTED CASSETTE TYPE

No.	Name of option	Remark	Kit name	
			FFF50BV1	FFF60BV1
1	Decoration panel		BYFQ60B3W1	
2	Sealing material of air discharge outlet		KDBH44BA60	
3	Panel spacer		KDBQ44BA60A	
4	Fresh air intake kit	Direct installation type	KDDQ44XA60	
5	Replacement long-life filter		KAFQ441BA60	
6	Remote controller	Wireless type Cooling only	BRC7E531W	
7	Navigation remote controller	Wired type <sup>1</sup>	BRC1E63	
8	Central remote controller <sup>2</sup>		DCS302CA61	
9	Unified ON/OFF controller <sup>2</sup>		DCS301BA61	
10	Schedule timer <sup>2</sup>		DST301BA61	
11	intelligent Touch Controller <sup>2</sup>		DCS601C51	
12	Adaptor for wiring <sup>3</sup>		KRP1BA57	
13	Wiring adaptor for electrical appendices (2) <sup>3</sup>		KRP4AA53	
14	Installation box for adaptor PCB		KRP1BA101	
15	Remote sensor (for indoor temperature)		BRCS01A-1	
16	Interface adaptor for SkyAir series		DTA112BA51	

Note:  
<sup>1</sup> Wiring for wired remote controller should be obtained locally.  
<sup>2</sup> This optional accessory requires DTA112BA51.  
<sup>3</sup> Installation box for adaptor PCB (KRP1BA101) is necessary.

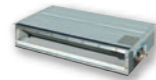

CEILING MOUNTED SLIM DUCT TYPE

No.	Name of option	Remark	Kit name	
			FDF50BV1	FDF60BV1
1	Remote controller	Wireless type Cooling only	BRC4C64	
2	Navigation remote controller	Wired type <sup>1</sup>	BRC1E63	
3	Remote sensor (for indoor temperature)		BRCS01A-1	
4	Insulation kit for high humidity		KDT25N63	

Note:  
<sup>1</sup> Wiring for wired remote controller should be obtained locally.



DUCT CONNECTION MIDDLE STATIC PRESSURE TYPE

No.	Name of option	Remark	Kit name					
			FBA50BVMA	FBA60BVMA	FBA71BVMA	FBA100BVMA	FBA125BVMA	FBA140BVMA
1	High-efficiency filter <sup>1</sup>	65%		KAFP632C80			KAFP632C160	
		90%		KAFP633C80			KAFP633C160	
2	Filter chamber(for rear suction) <sup>1</sup>		KDDFP63B80			KDDFP63B160		
3	Long-life filter <sup>1</sup>		KAFP631B80			KAFP631B160		
4	Service panel	White	KTBJ25K80W			KTBJ25K160W		
		Fresh white	KTBJ25K80F			KTBJ25K160F		
		Brown	KTBJ25K80T			KTBJ25K160T		
5	Air discharge adaptor		KDAP25A71A			KDAP25A140A		
6	Shield plate for side plate		KDBD63A160					
7	Remote controller	Wireless type	BRC4C66					
		Cooling only Heat pump						
8	Navigation Remote Controller	Wired type <sup>2</sup>	BRC1E63					
9	Adaptor for wiring		KRP1C64 *					
10	Wiring adaptor for electrical appendices(2)		KRP4AA51 *					
11	Mounting plate for adaptor PCB <sup>3,4,5</sup>		KRP4A98					
12	Remote sensor (for indoor temperature)		BRCS01A-4					
13	Central remote controller <sup>6</sup>		DCS302CA61					
14	Unified ON/OFF controller <sup>6</sup>		DCS301BA61					
15	Schedule timer <sup>6</sup>		DST301BA61					
16	intelligent Touch Controller <sup>6</sup>		DCS601C51					

Note: <sup>1</sup>If installing high efficiency filter and long-life filter to the unit, filter chamber is required.  
<sup>2</sup>Wiring for wired remote controller should be obtained locally.  
<sup>3</sup>Mounting plate is necessary for each adaptor marked ★.  
<sup>4</sup>Up to 2 adaptors can be fixed for each mounting plate.  
<sup>5</sup>Only one mounting plate can be installed for each indoor unit.  
<sup>6</sup>The indoor unit is equipped standardly with the interface adaptor for SkyAir series. An option is unnecessary.

Indoor unit



CEILING SUSPENDED TYPE

No.	Name of option	Remark	Kit name					
			FHA50BVMV	FHA60BVMV	FHA71BVMV	FHA100BVMV	FHA125BVMV	FHA140BVMV
1	Replacement long-life filter	Resin net	KAFP501A56		KAFP501A80		KAFP501A160	
2	Fresh air intake kit		KDDQ50A140					
3	Drain pump kit		KDUP50R160					
4	L-type piping kit (for upward direction)		KHFP5N160					
5	Remote controller	Wireless type	BRC7M56					
		Cooling only Heat pump						
6	Navigation Remote Controller	Wired type <sup>1</sup>	BRC1E63					
7	Central remote controller <sup>2</sup>		DCS302CA61					
8	Unified ON/OFF controller <sup>2</sup>		DCS301BA61					
9	Schedule timer <sup>2</sup>		DST301BA61					
10	intelligent Touch Controller <sup>2</sup>		DCS601C51					
11	Adaptor for wiring <sup>3</sup>		KRP1BA54					
12	Wiring adaptor for electrical appendices <sup>3</sup>		KRP4AA52					
13	Installation box for adaptor PCB		KRP1D93A					
14	Adaptor box mounting plate		KKSAP50A56					
15	Remote sensor (for indoor temperature)		BRCS01A-4					
16	Electrical box with earth terminal (3 blocks)		KJB311AA					
17	Electrical box with earth terminal (2 blocks)		KJB212AA					

Note:  
<sup>1</sup> Wiring for wired remote controller should be obtained locally.  
<sup>2</sup> The indoor unit is equipped standardly with the interface adaptor for SkyAir series. An option is unnecessary.  
<sup>3</sup> Installation box for adaptor PCB (KRP1D93A) is necessary.



FLOOR STANDING TYPE

No.	Name of option	Remark	Kit name					
			FVA50AMVM	FVA60AMVM	FVA71AMVM	FVA100AMVM	FVA125AMVM	FVA140AMVM
1	Replacement long life filter		KAFJ95L160					
2	Remote controller	Wireless type Cooling only	BRC4C66					
3	Navigation Remote Controller	Wired type <sup>1</sup>	BRC1E63					
4	Central remote controller <sup>2</sup>		DCS302CA61					
5	Unified ON/OFF controller <sup>2</sup>		DCS301BA61					
6	Schedule timer <sup>2</sup>		DST301BA61					
7	intelligent Touch Controller <sup>2</sup>		DCS601C51					
8	Adaptor for wiring <sup>3</sup>		KRP1BA57					
9	Wiring adaptor for electrical appendices(2) <sup>3</sup>		KRP4AA52					
10	Installation box for adaptor PCB		KRP4AA95					

Note: <sup>1</sup> Wiring for wired remote controller should be obtained locally.  
<sup>2</sup> The indoor unit is equipped standardly with the interface adaptor for SkyAir series. An option is unnecessary.  
<sup>3</sup> Installation box for adaptor PCB (KRP4AA95) is necessary.

Outdoor unit



No.	Name of option	Phase	Kit name			
			RZF50/60/71CV2V	RZF100CVM	RZF125/140CVM	—
		3 Phase	—	RZF71/100CYM	RZF125/140CYM	—
		1 Phase	—	—	—	RZA71/100BV2V
1	Central drain plug		KKP014A4	KKP937A4	KKPJ5G280	KKPJ5G280
2	Fixture for preventing overturning		—	—	KKTP5B112	KKTP5B112
3	Wire fixture for preventing overturning		—	—	K-KYZP15C	K-KYZP15C
4	Demand adaptor		—	KRP58M51	KRP58M51+EKMKSA1	KRP58M51+EKMKSA1
5	Overvoltage PCB	1 Phase	BRV2BPSP	BRV2BPSS	BRV2BPL	—
		3 Phase	—	BRV2BPSS+BRV2BPSS	—	—

**CEILING MOUNTED CASSETTE TYPE / Standard panel with Sensing**

[FCF50-71CVM]

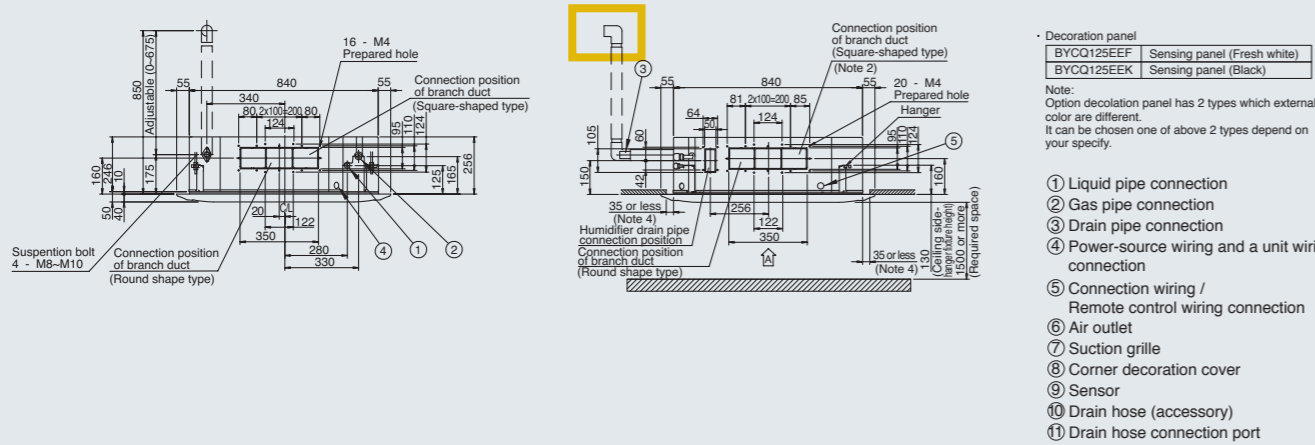
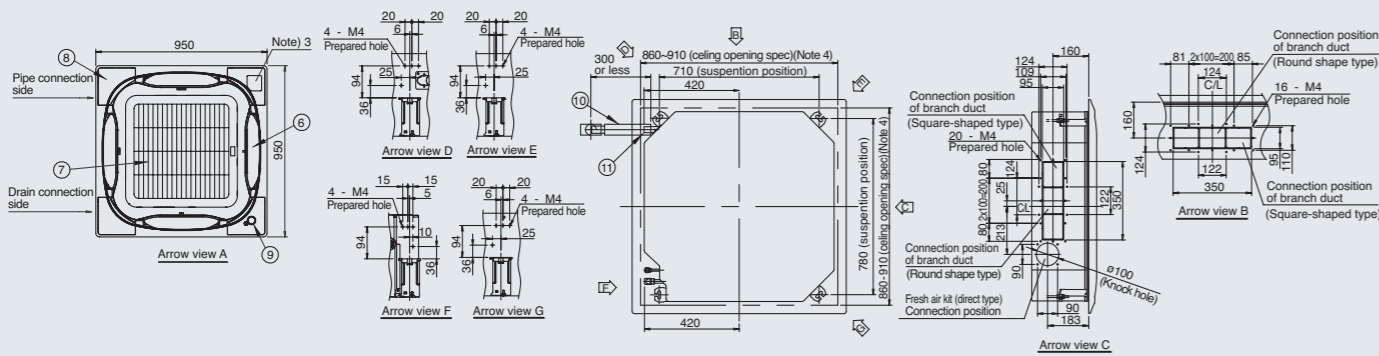

- Note:
1. Sticking location for Manufacturer's label  
 Manufacturer's label for Indoor unit : Suction grille inner side's electric components box's lid surface.  
 Manufacturer's label for Decoration panel : Decoration panel's corner decoration cover inner surface.
  2. In case of having option part built-in, please refer outside drawing of option part.  
 Fresh air intake kit.....inspection hole Need  
 Natural evaporate type humidifier.....inspection hole No Need  
 Air purifier unit.....inspection hole No Need  
 High efficiency filter unit.....inspection hole No Need  
 Branch duct chamber.....inspection hole No Need  
 (both angle duct + circle duct)
  3. In case of using wireless remote controller, this position will be a signal receiver. Refer to the drawing of wireless remote controller in detail.
  4. Though the installation is acceptable up to maximum of 910 mm square ceiling opening, keep the clearance of 35mm or less between the indoor unit and the ceiling opening so that the panel overlap allowance can be ensured.
  5. When the temperature and humidity in the ceiling exceed 30°C and 80% RH or the fresh air is inducted into the ceiling or the unit continues 24 hour operation, an additional insulation (thickness 10mm or more of glasswool or polyethylene form) is required.
  6. Please do not place the thing been damp and troubled under an indoor unit. when the case where humidity is 80% or more, and the drain outlet are choked up and the air filter are dirty, dew may fall.
  7. If put vent hole, lighting, equipment near the air flow disturb equipment, ceiling surface may get dirty, therefore shall install following to diagram as below.

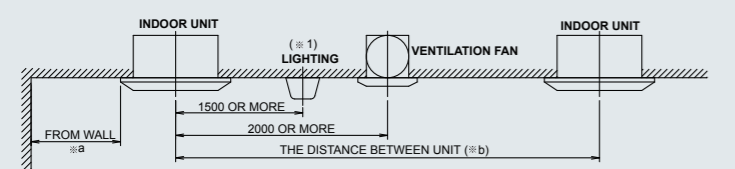
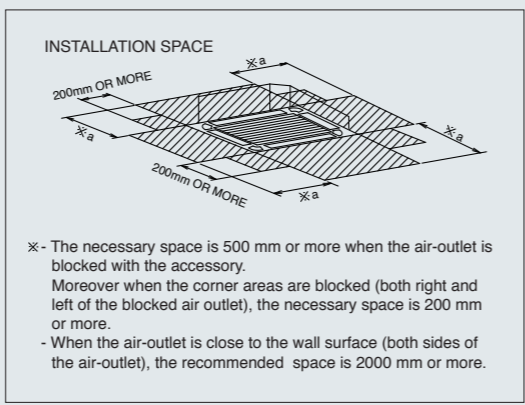

8. For fixing position of human detection and temp sensor will be follow to diagram instruction (can not change position).

Model		FCF50-71CVM	
Circulation air flow	Valid	※a	1500-5000
		※b	5000 or more
	Invalid	※a	1500 or more
		※b	4000 or more

(※ 1)Lighting is targeted for exposed type (inverse fuji-shape etc.), for embedded type (type that not expose to ceiling surface), there is no restriction.

**CEILING MOUNTED CASSETTE TYPE / Standard panel with Sensing**

[FCF100-140CVM]

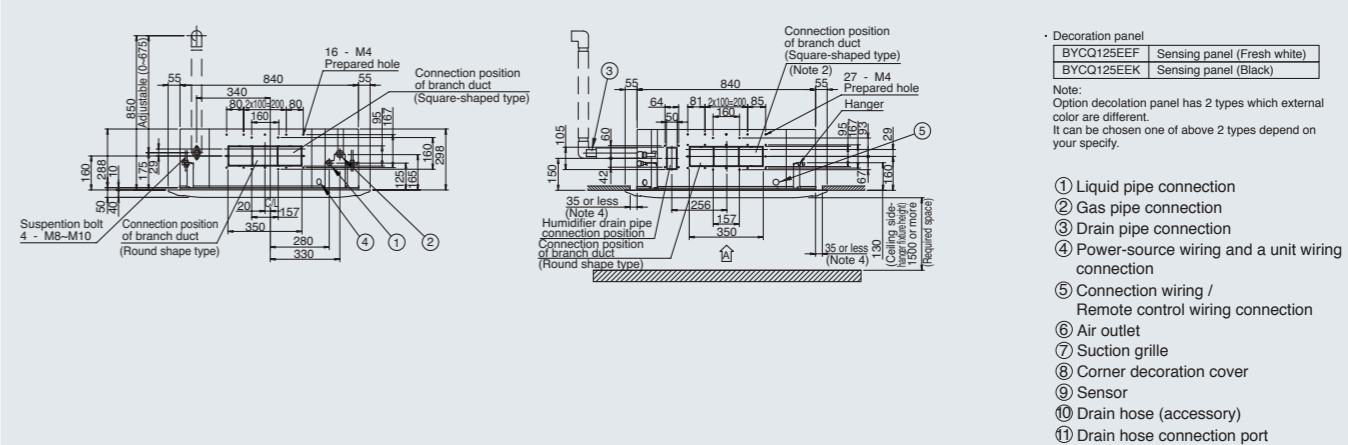
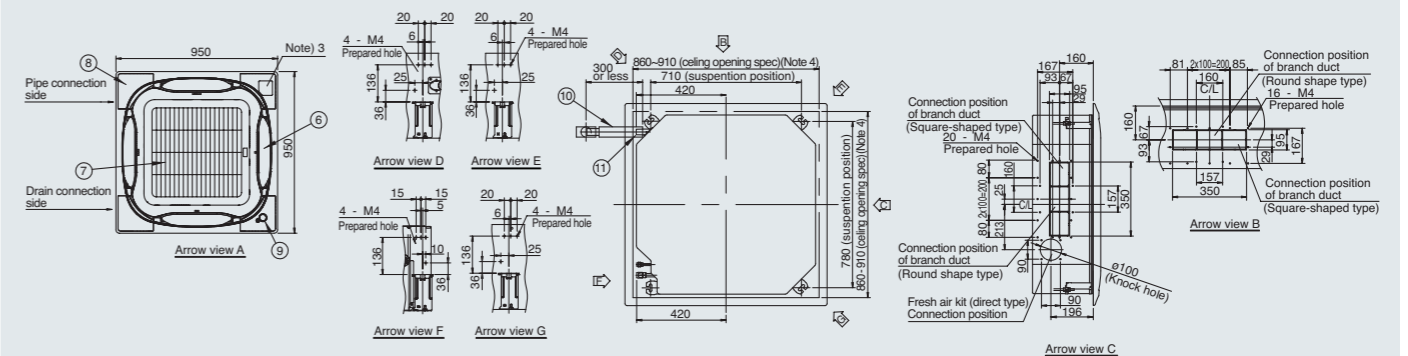

- Note:
1. Sticking location for Manufacturer's label  
 Manufacturer's label for Indoor unit : Suction grille inner side's electric components box's lid surface.  
 Manufacturer's label for Decoration panel : Decoration panel's corner decoration cover inner surface.
  2. In case of having option part built-in, please refer outside drawing of option part.  
 Fresh air intake kit.....inspection hole Need  
 Natural evaporate type humidifier.....inspection hole No Need  
 Air purifier unit.....inspection hole No Need  
 High efficiency filter unit.....inspection hole No Need  
 Branch duct chamber.....inspection hole No Need  
 (both angle duct + circle duct)
  3. In case of using wireless remote controller, this position will be a signal receiver. Refer to the drawing of wireless remote controller in detail.
  4. Though the installation is acceptable up to maximum of 910 mm square ceiling opening, keep the clearance of 35mm or less between the indoor unit and the ceiling opening so that the panel overlap allowance can be ensured.
  5. When the temperature and humidity in the ceiling exceed 30°C and 80% RH or the fresh air is inducted into the ceiling or the unit continues 24 hour operation, an additional insulation (thickness 10mm or more of glasswool or polyethylene form) is required.
  6. Please do not place the thing been damp and troubled under an indoor unit. when the case where humidity is 80% or more, and the drain outlet are choked up and the air filter are dirty, dew may fall.
  7. If put vent hole, lighting, equipment near the air flow disturb equipment, ceiling surface may get dirty, therefore shall install following to diagram as below.

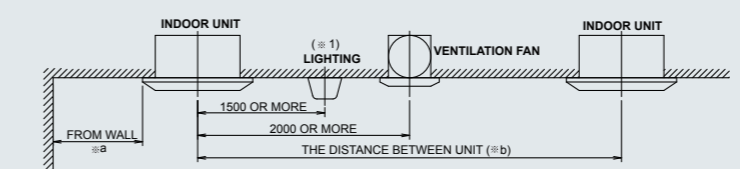
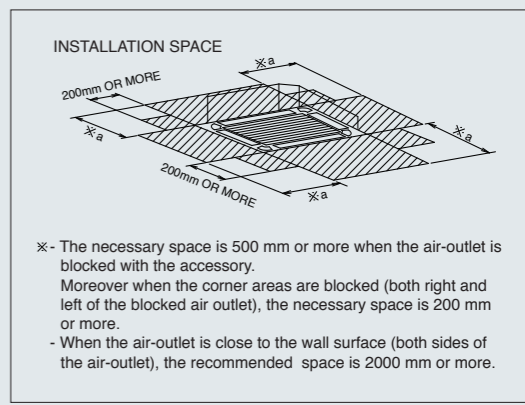

8. For fixing position of human detection and temp sensor will be follow to diagram instruction (can not change position).

Model		FCF100-140CVM	
Circulation air flow	Valid	※a	1500-7000
		※b	7000 or more
	Invalid	※a	1500 or more
		※b	4000 or more

(※ 1)Lighting is targeted for exposed type (inverse fuji-shape etc.), for embedded type (type that not expose to ceiling surface), there is no restriction.

**CEILING MOUNTED CASSETTE TYPE / Standard panel**

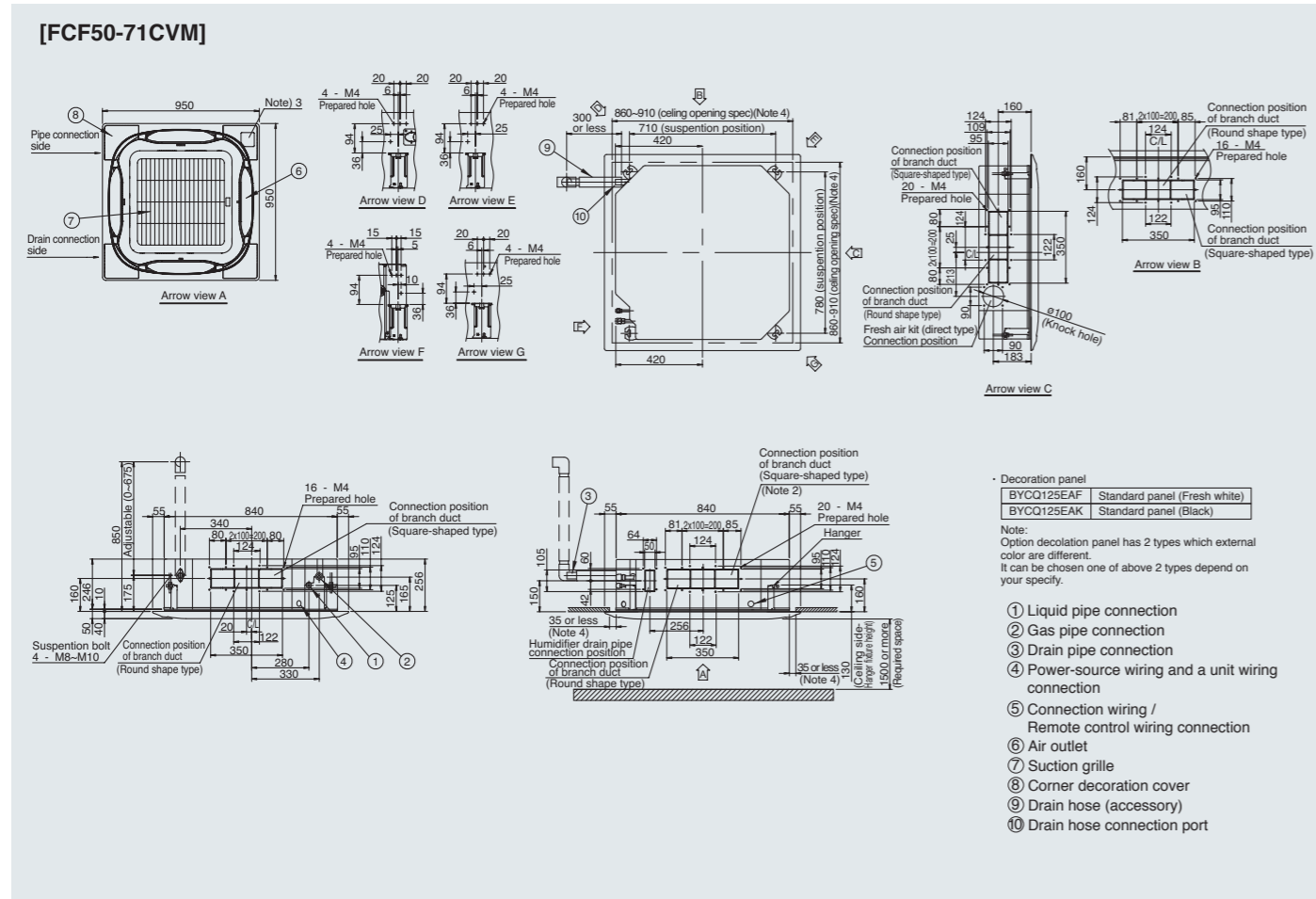

**CEILING MOUNTED CASSETTE TYPE / Designer panel**

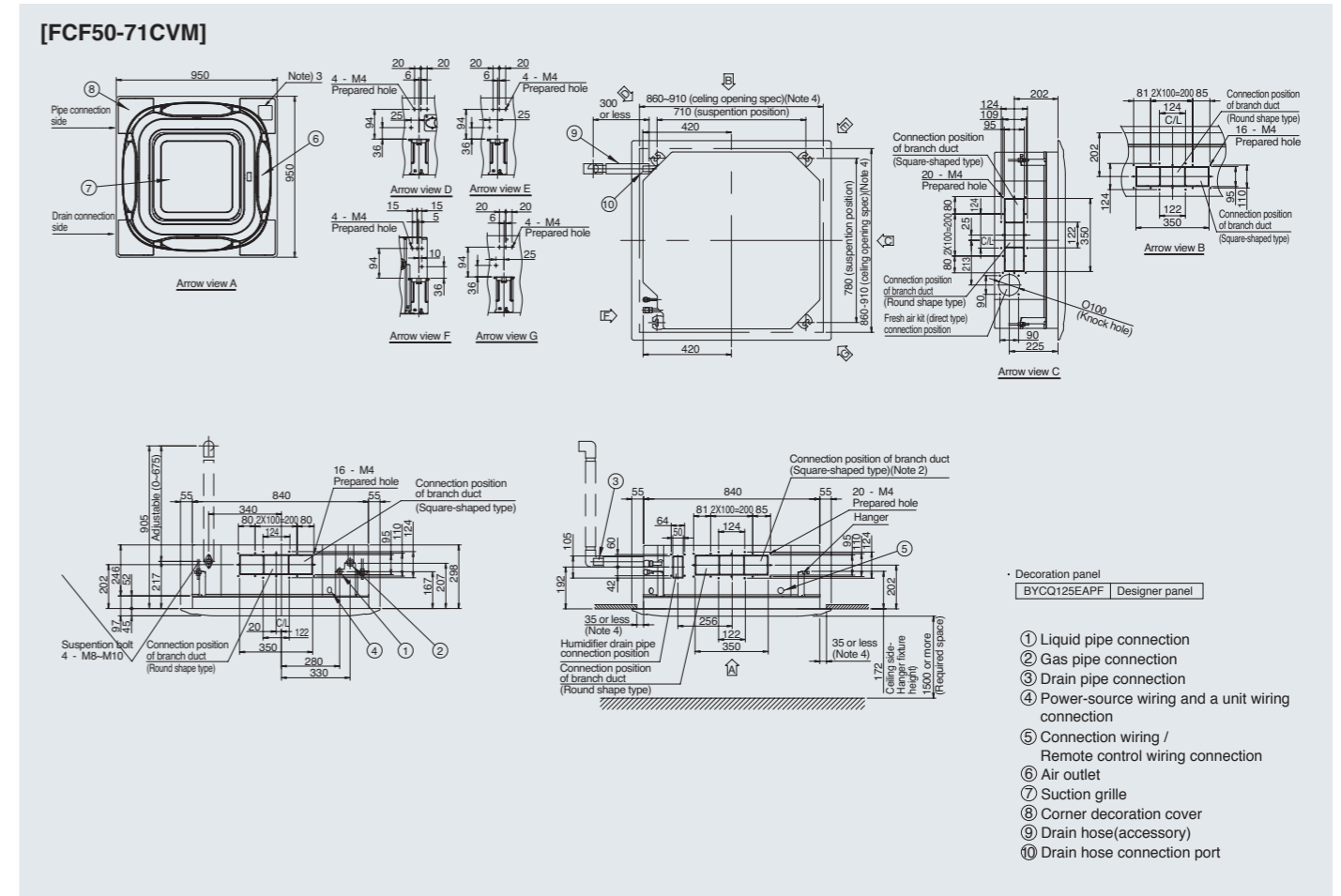

**CEILING MOUNTED CASSETTE TYPE / Standard panel**

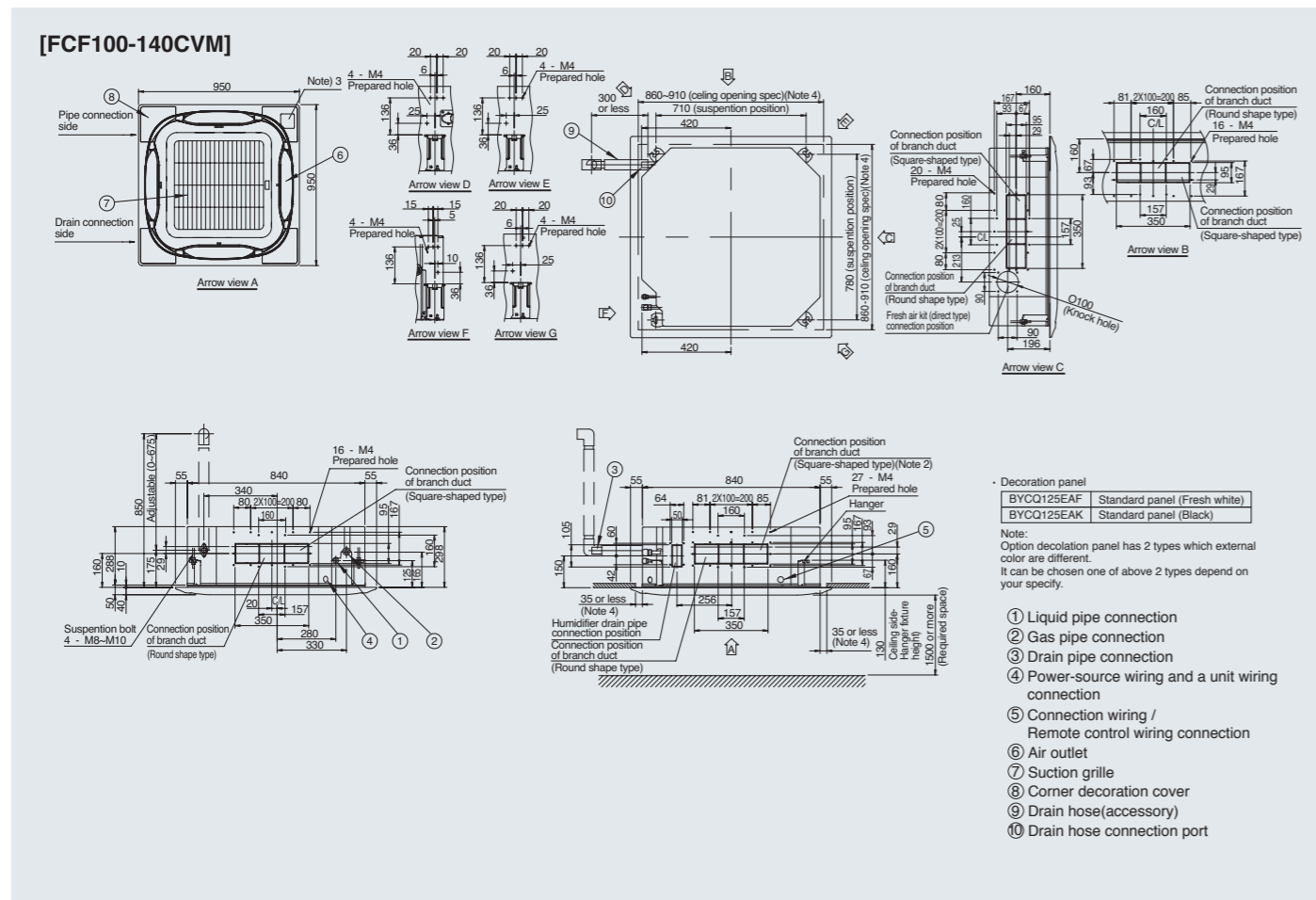

**CEILING MOUNTED CASSETTE TYPE / Designer panel**

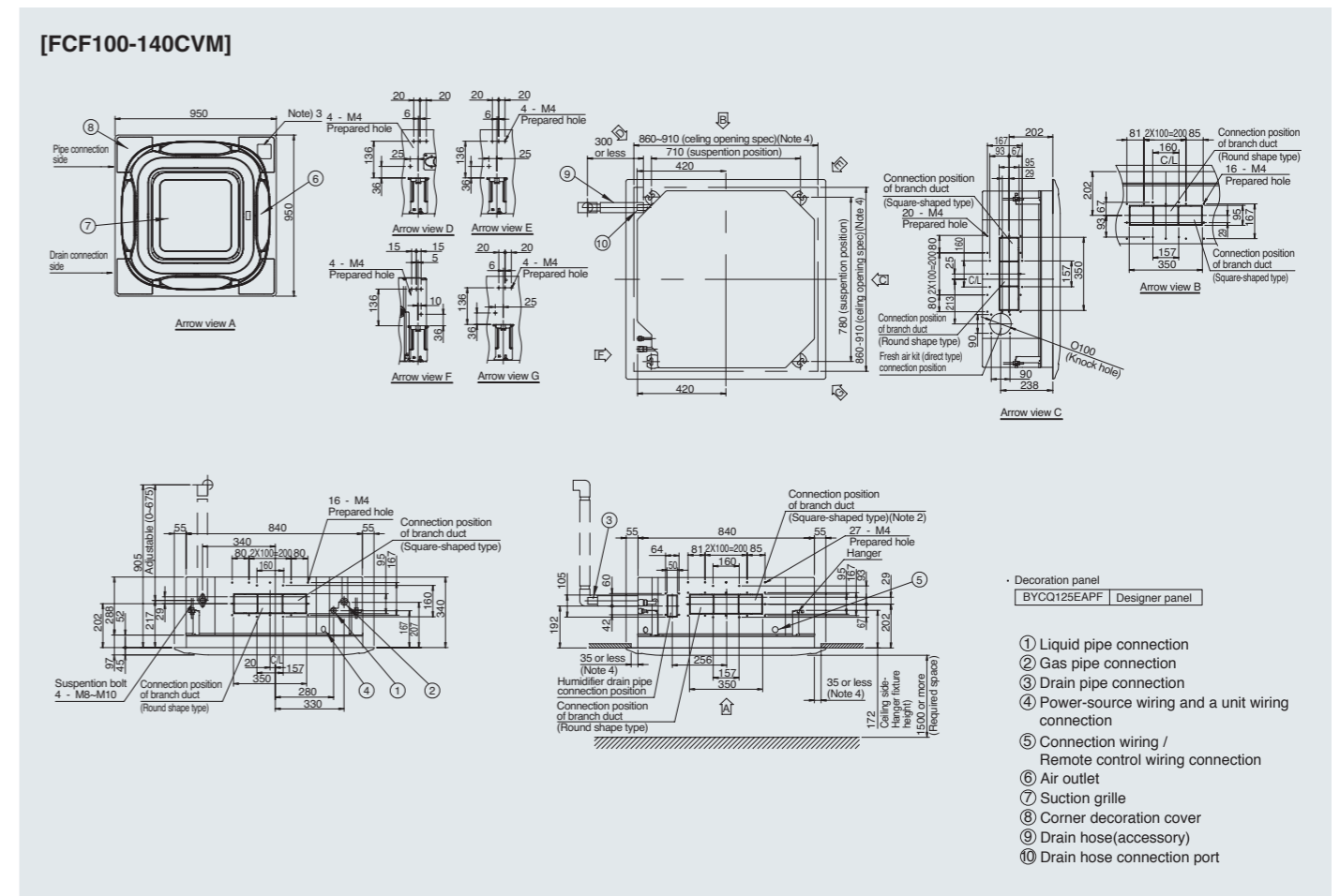

**CEILING MOUNTED CASSETTE TYPE / Auto grille panel**

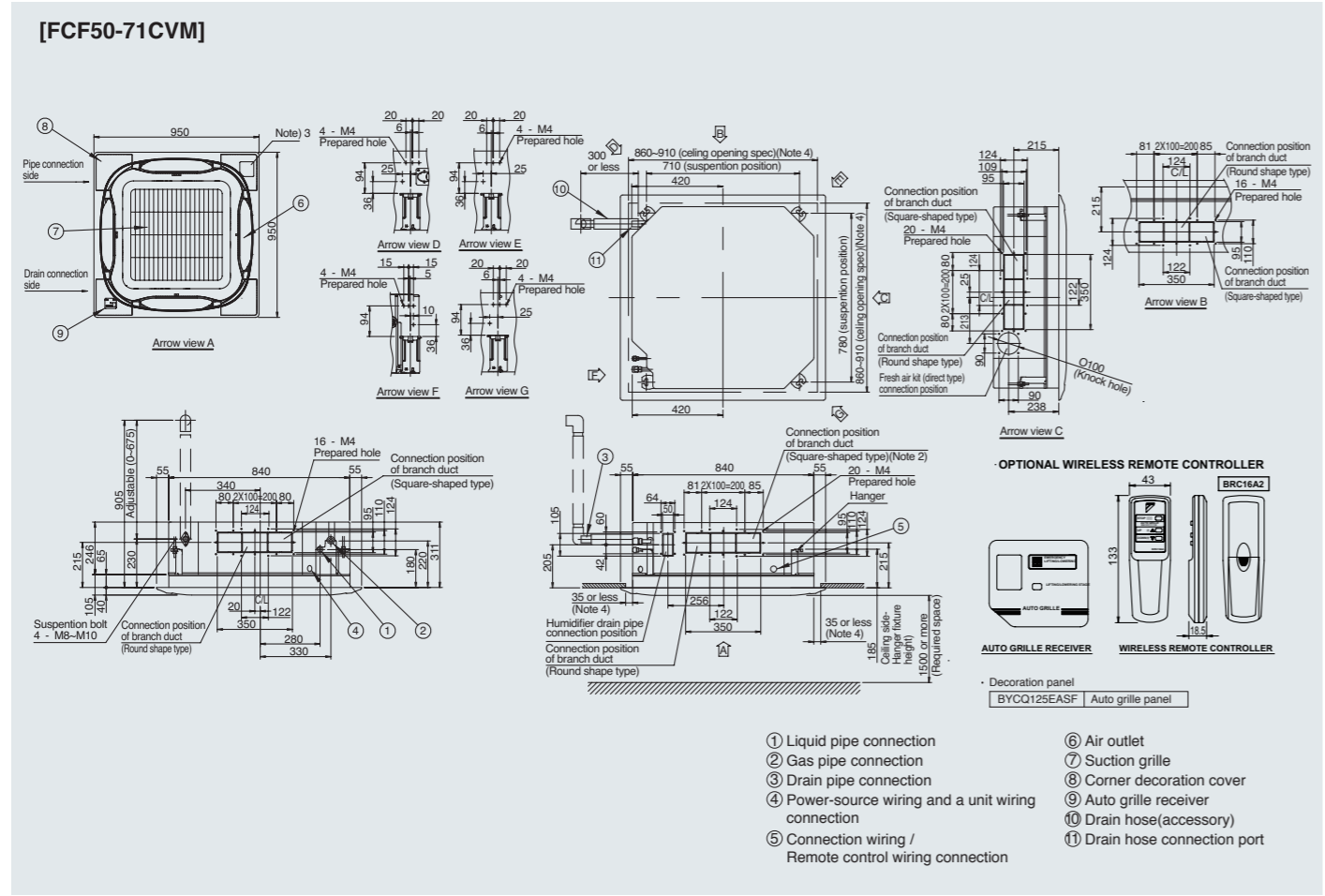

**COMPACT MULTI FLOW CEILING MOUNTED CASSETTE TYPE**

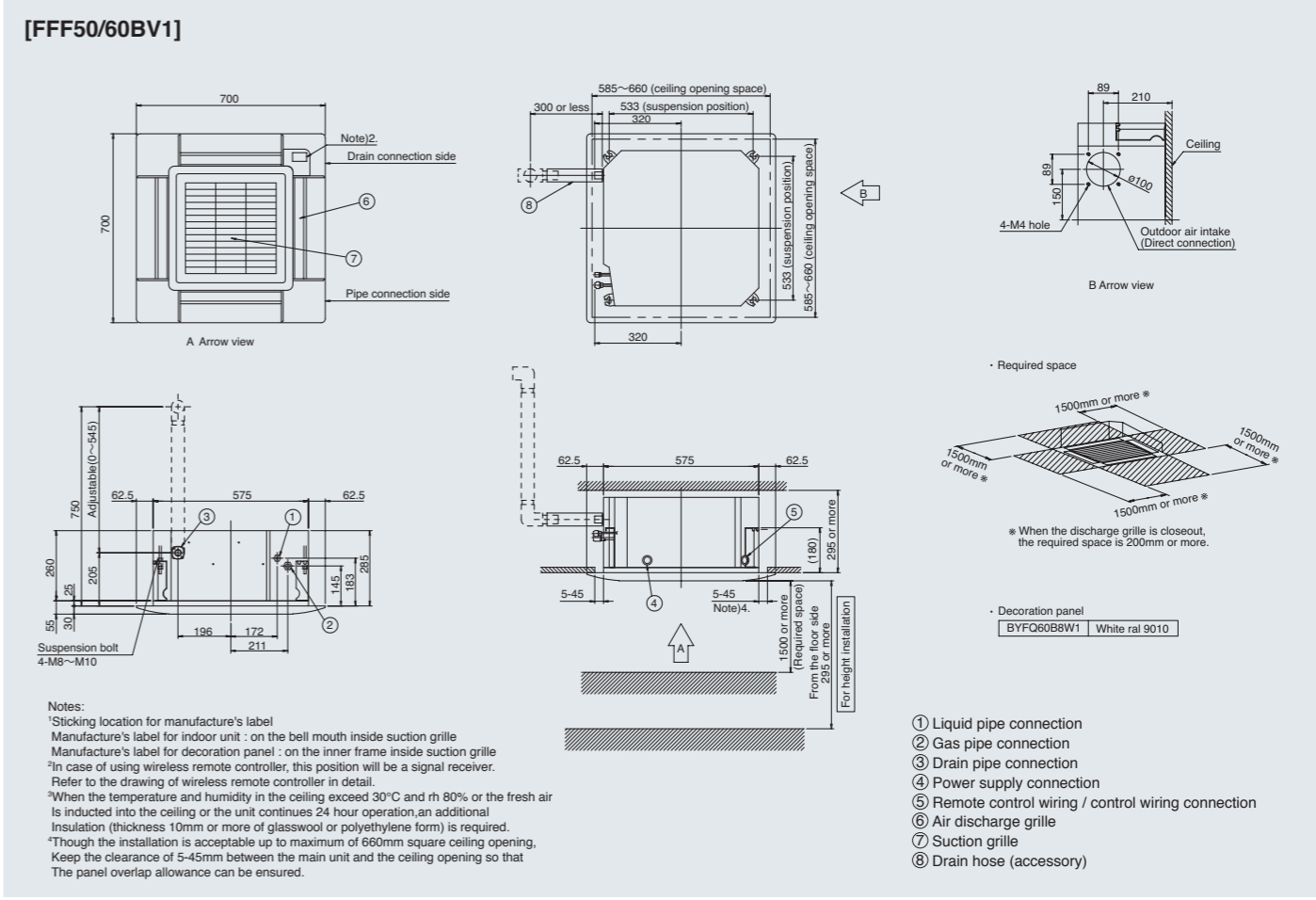

**CEILING MOUNTED CASSETTE TYPE / Auto grille panel**

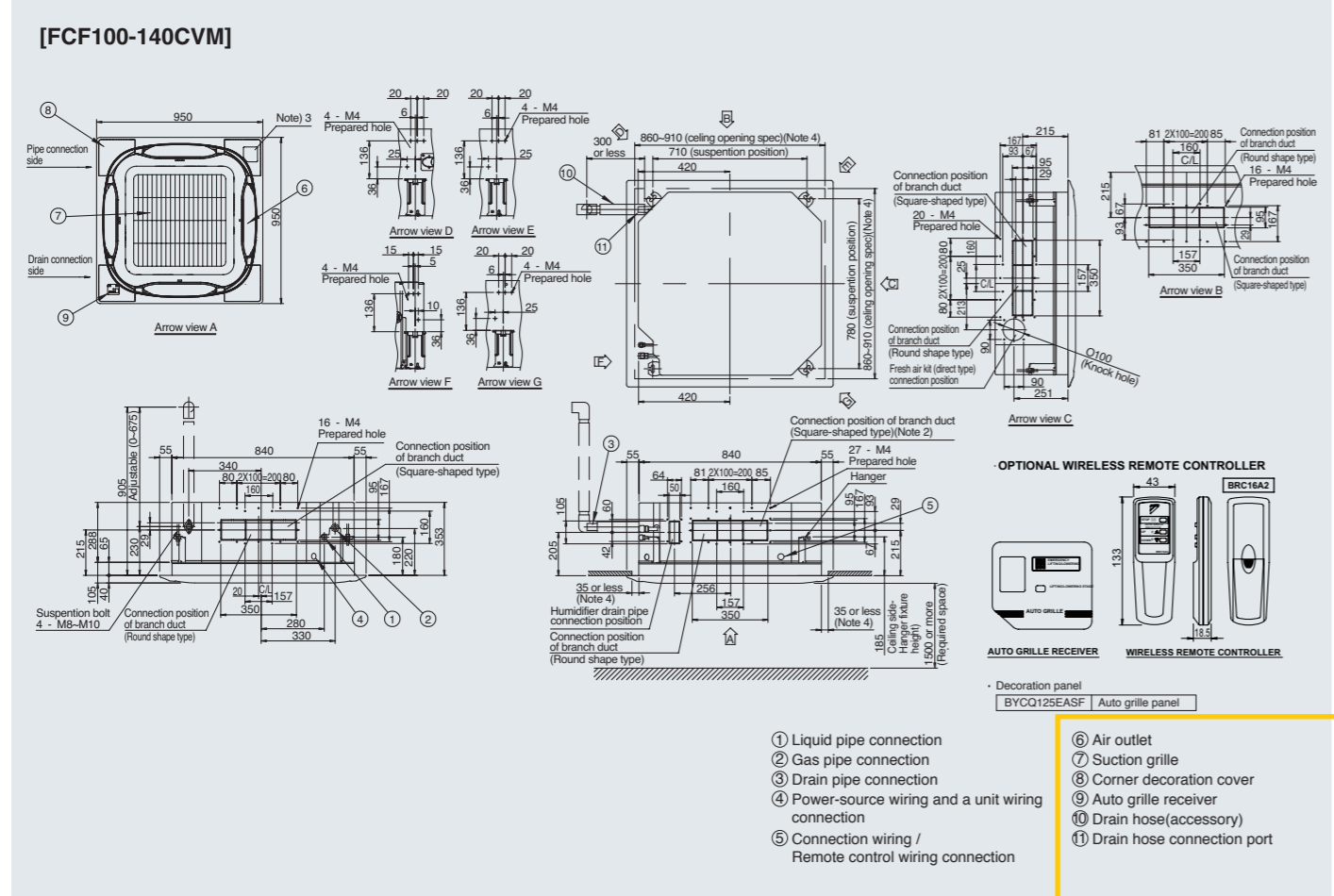

**CEILING MOUNTED SLIM DUCT TYPE**

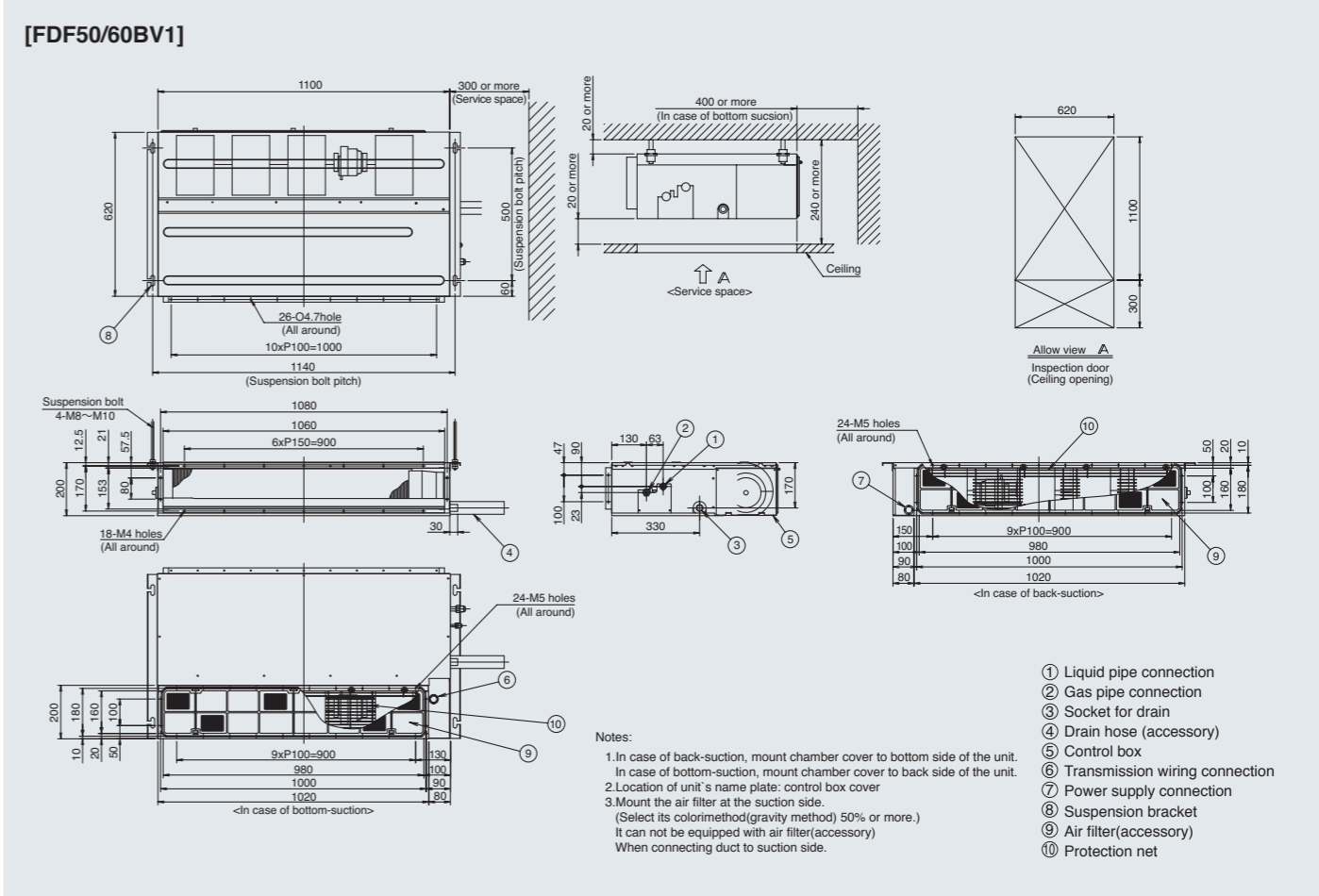

DUCT CONNECTION MIDDLE STATIC PRESSURE TYPE

[FBA50-71BVMA]

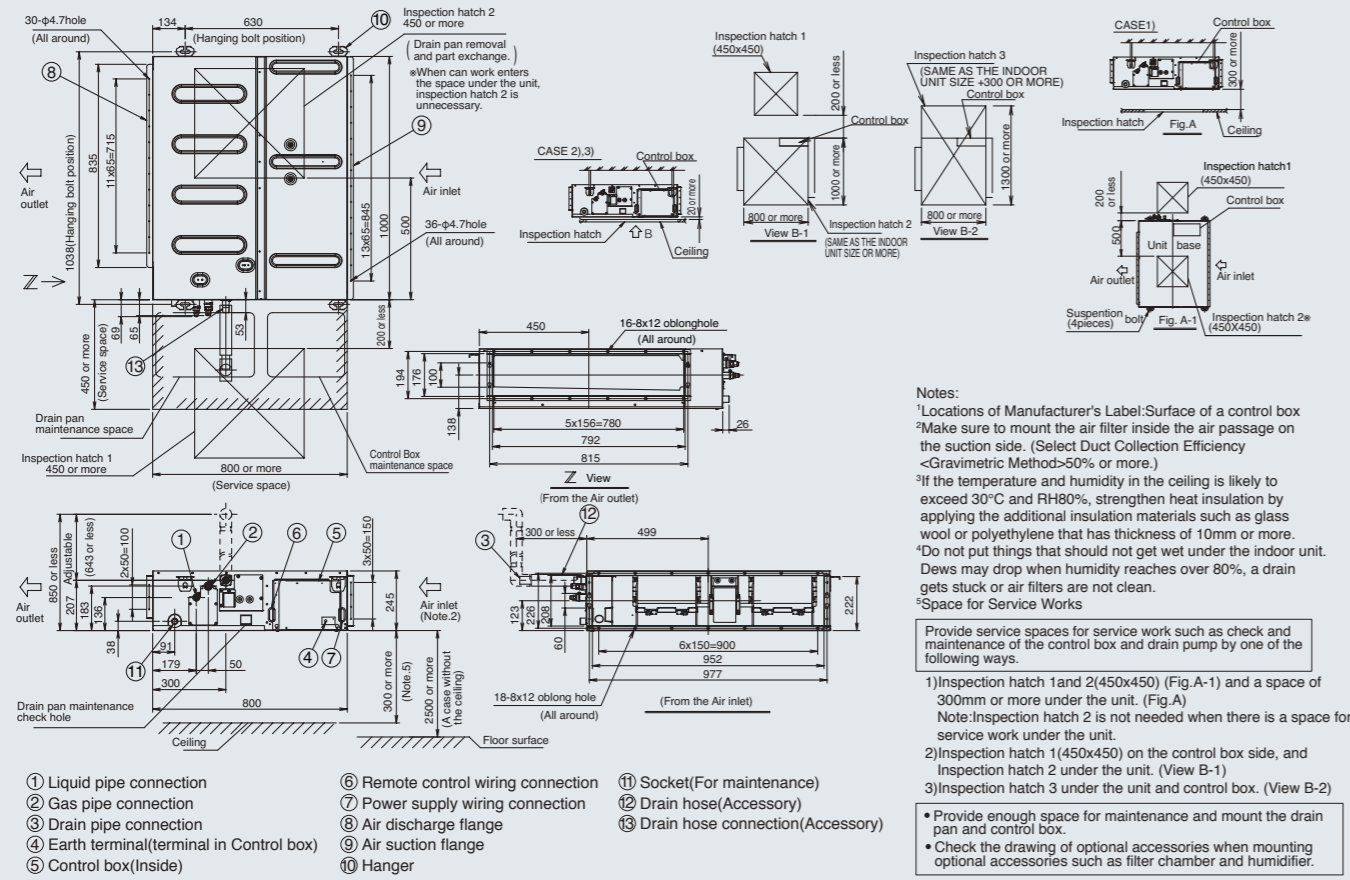

CEILING SUSPENDED TYPE

[FHA50/60BVMV]

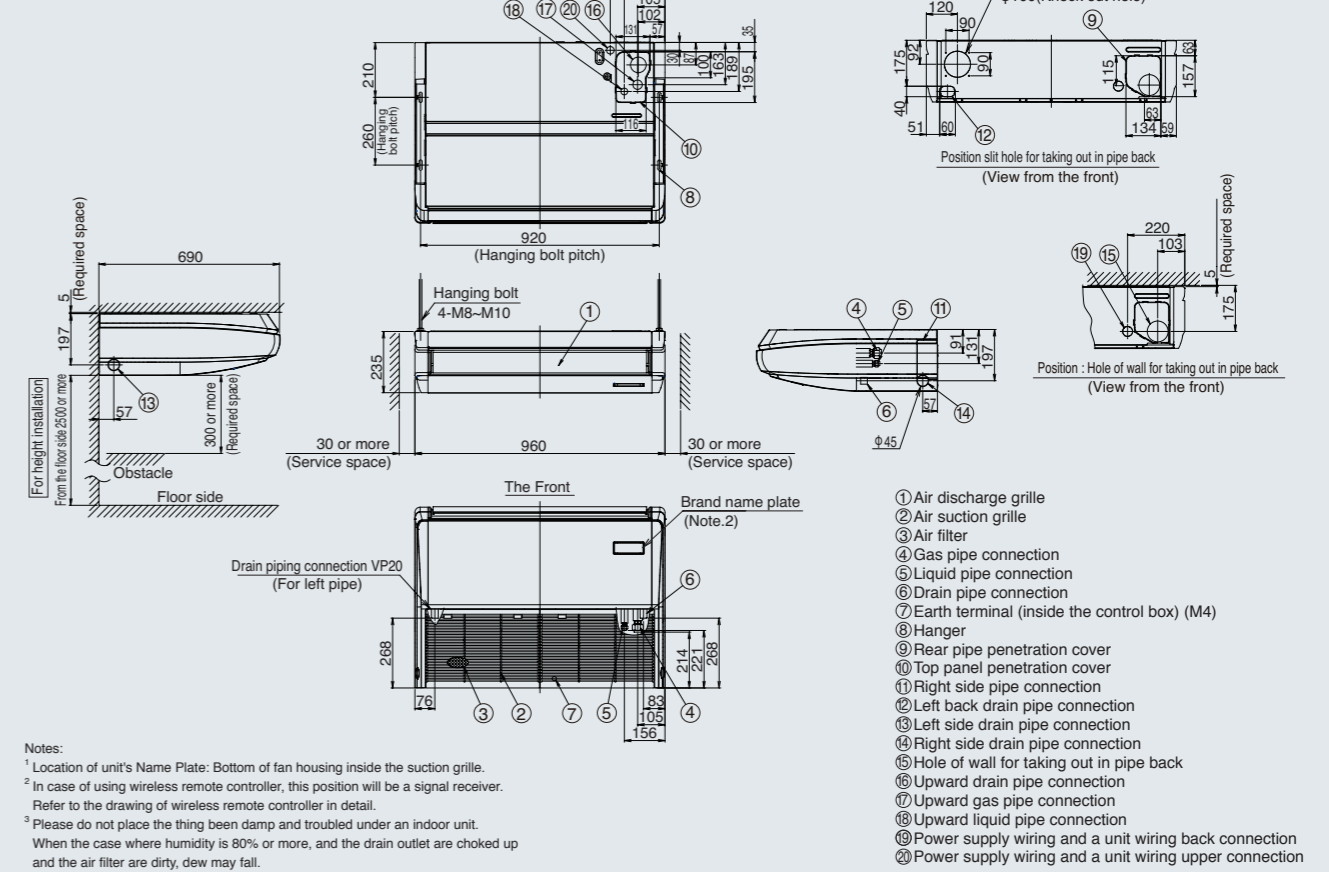

DUCT CONNECTION MIDDLE STATIC PRESSURE TYPE

[FBA100-140BVMA]

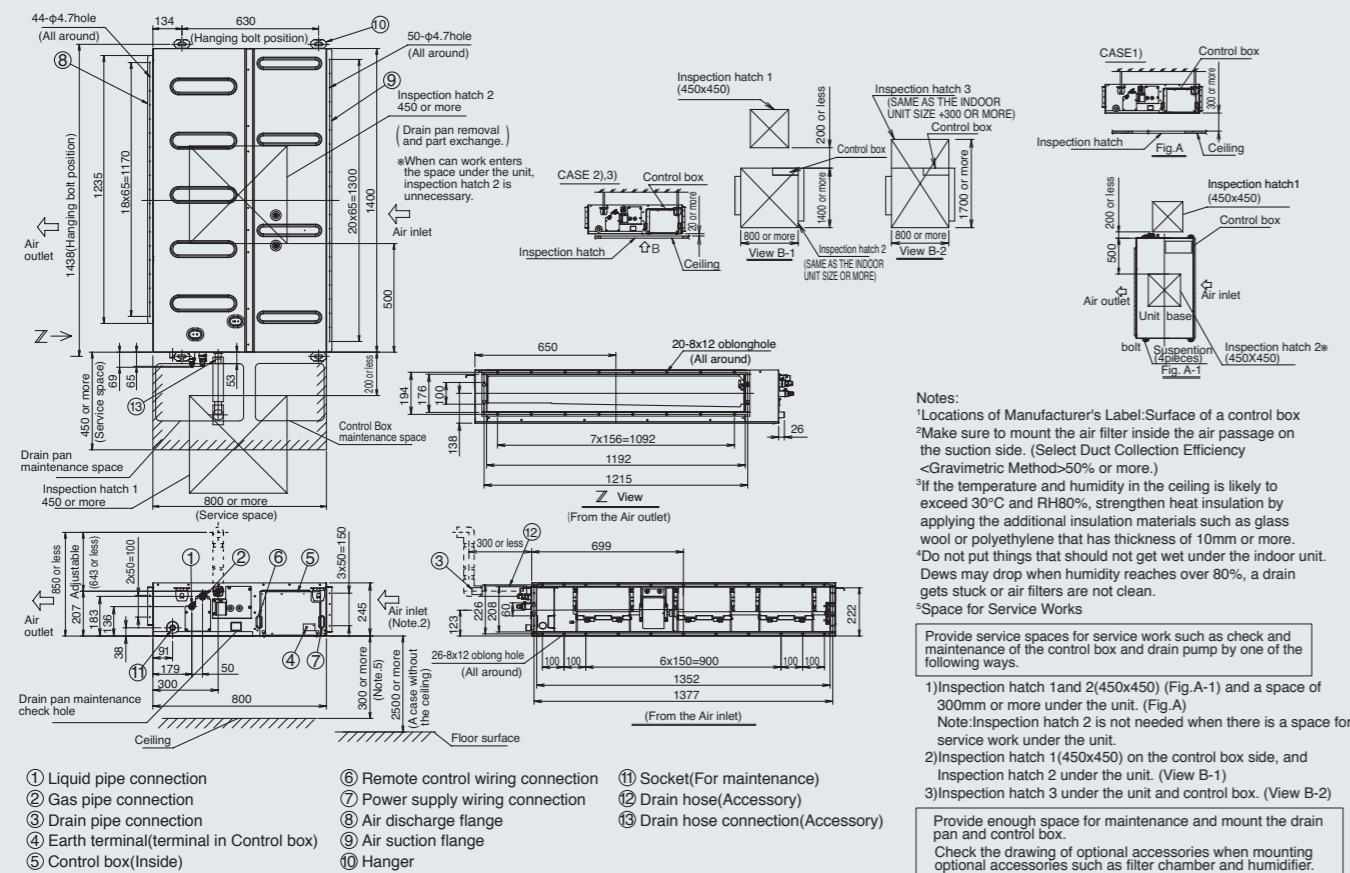

CEILING SUSPENDED TYPE

[FHA71BVMV]

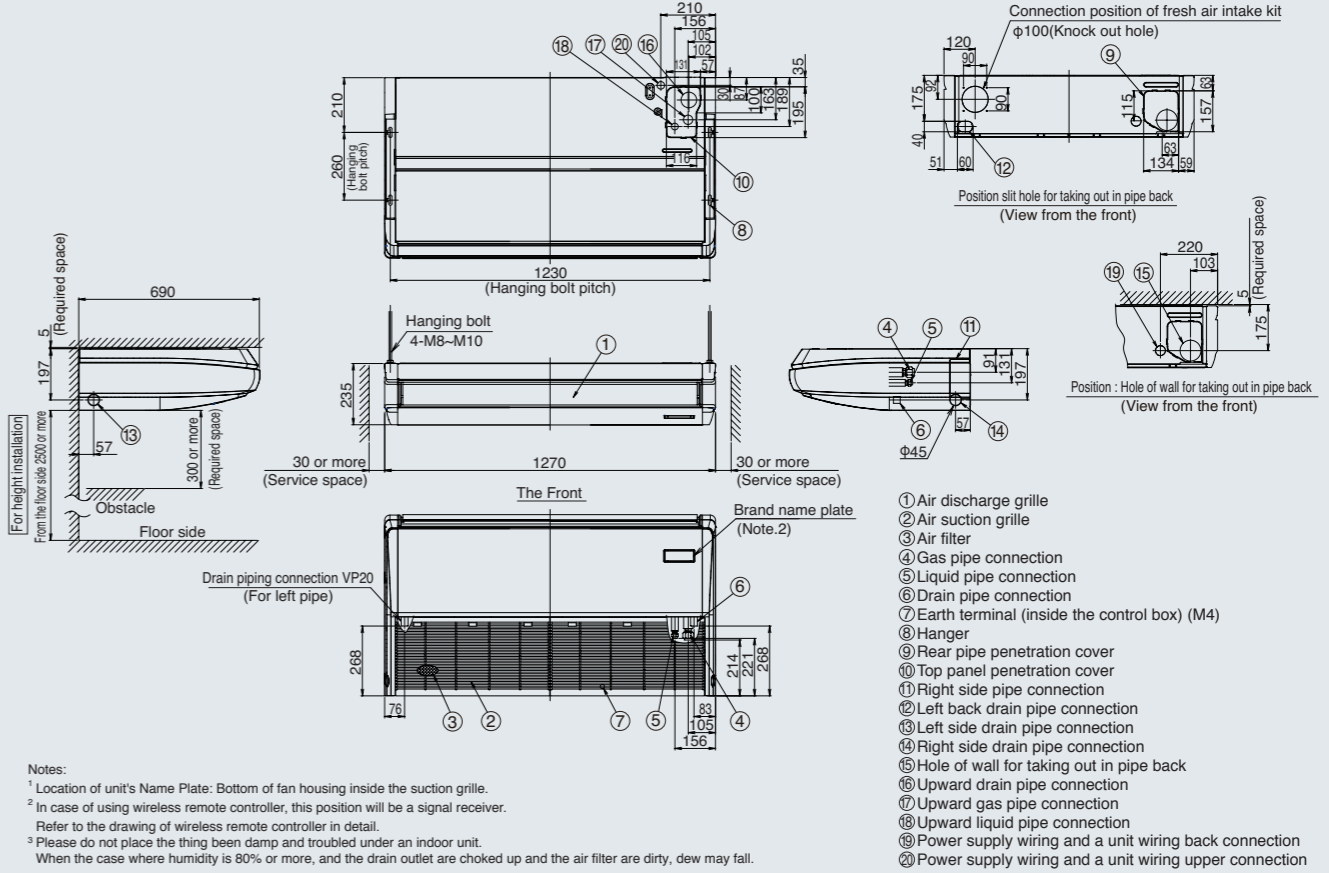

**CEILING SUSPENDED TYPE**

[FHA100BVMV, 125/140BVMA]

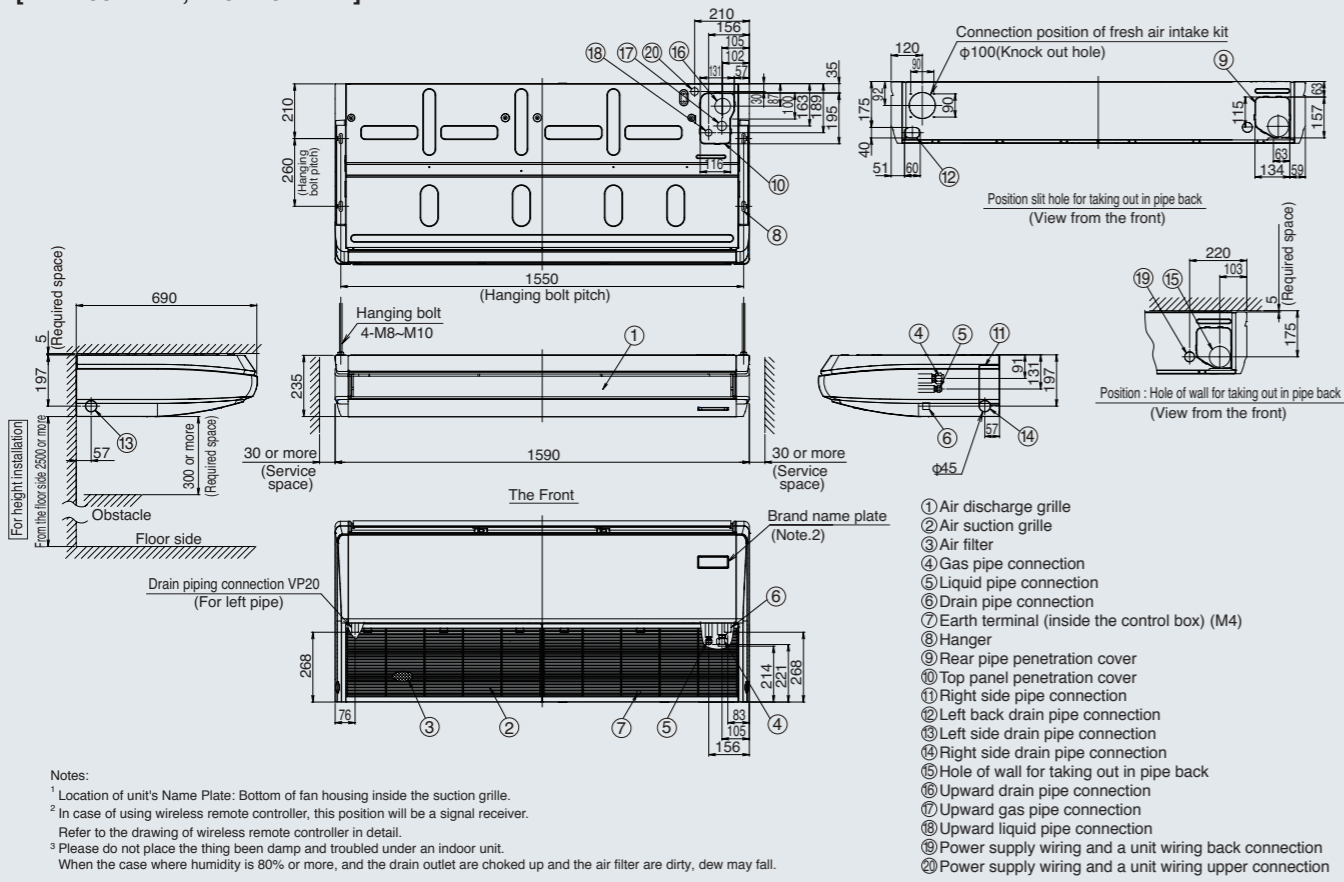

**FLOOR STANDING TYPE**

[FVA50-71 AMVM]

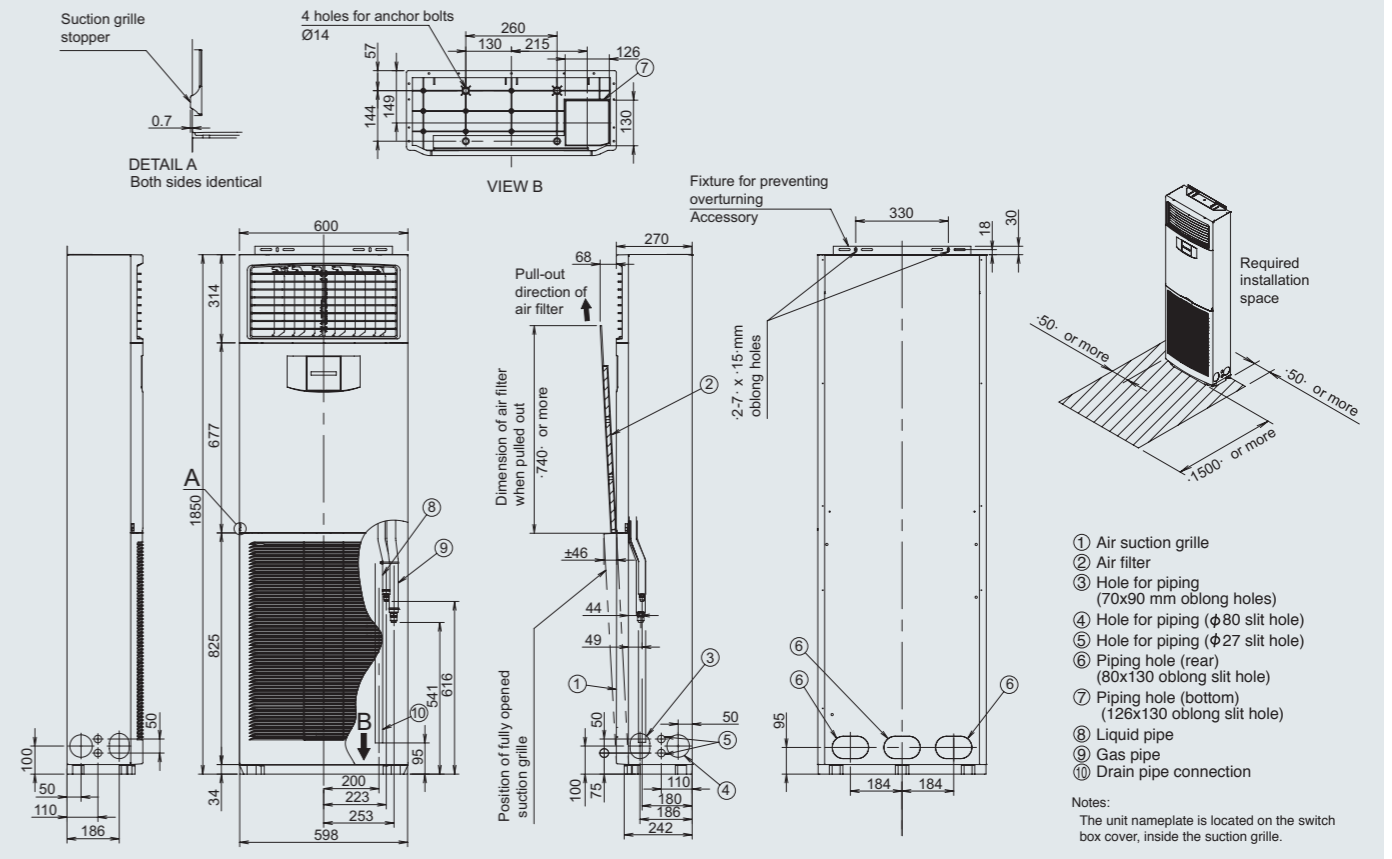

**FLOOR STANDING TYPE**

[FVA100-140AMVM]

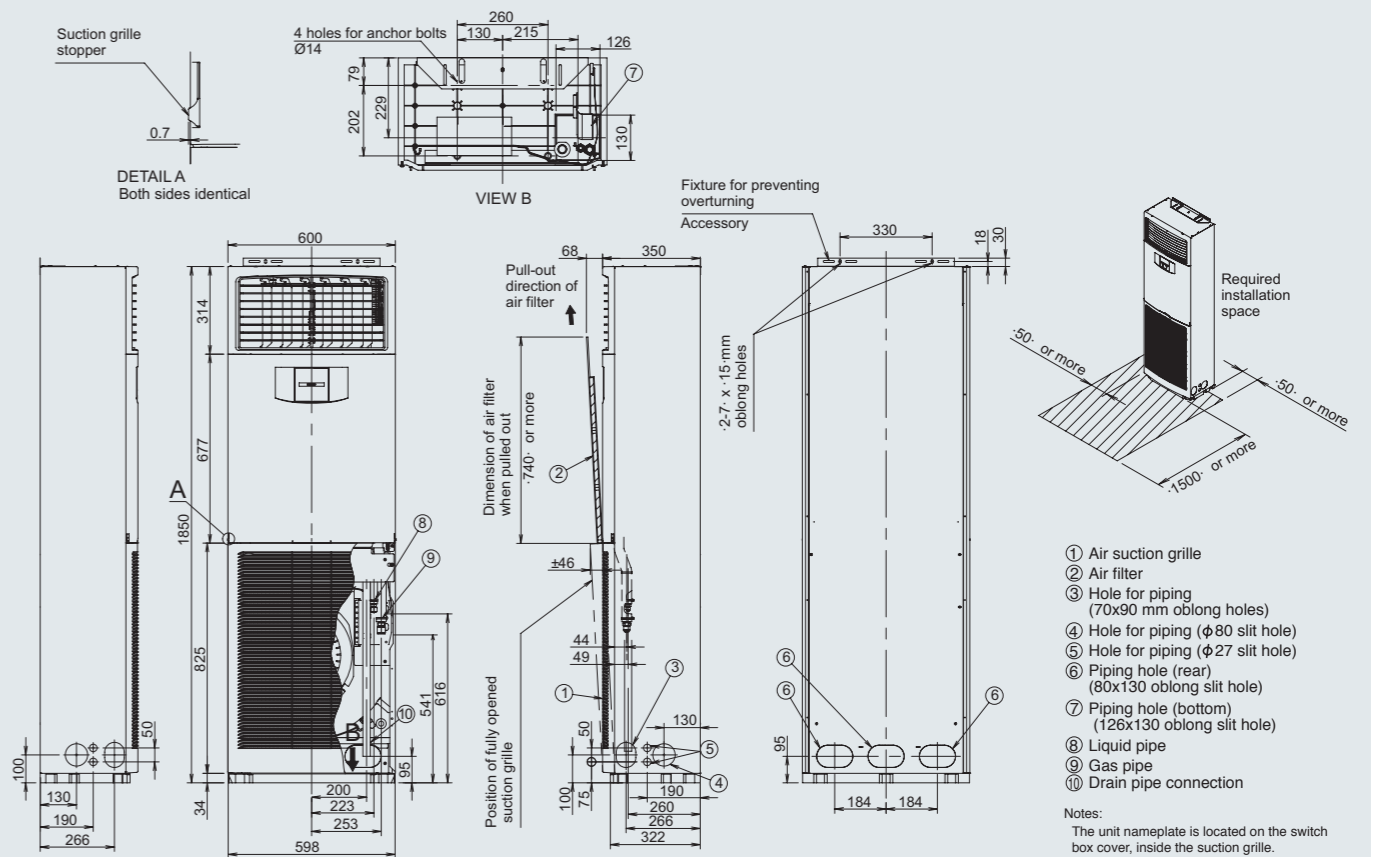

**OUTDOOR UNIT // RZF50/60/71CV2V**

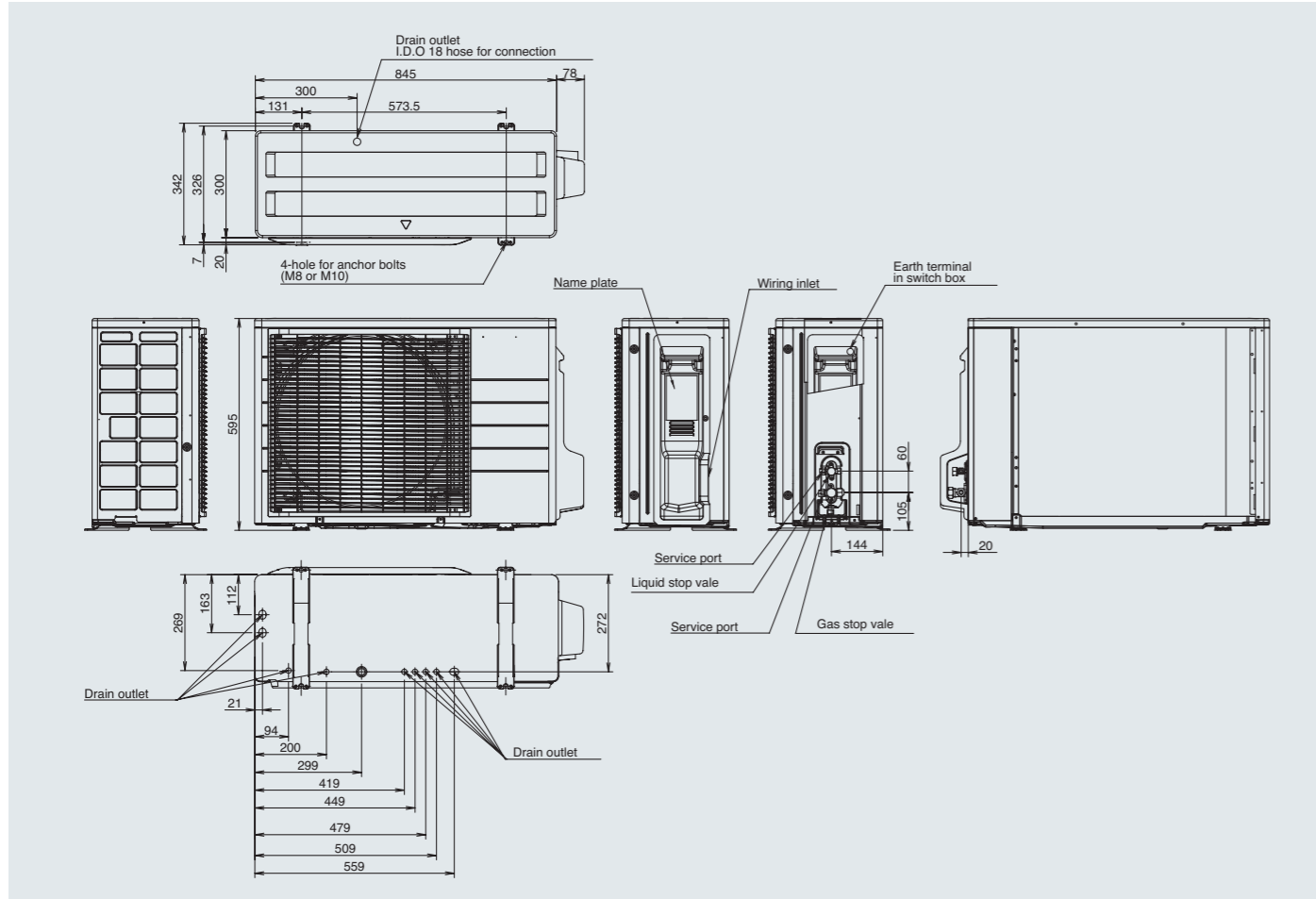

**OUTDOOR UNIT // RZF125/140CVM / CYM**

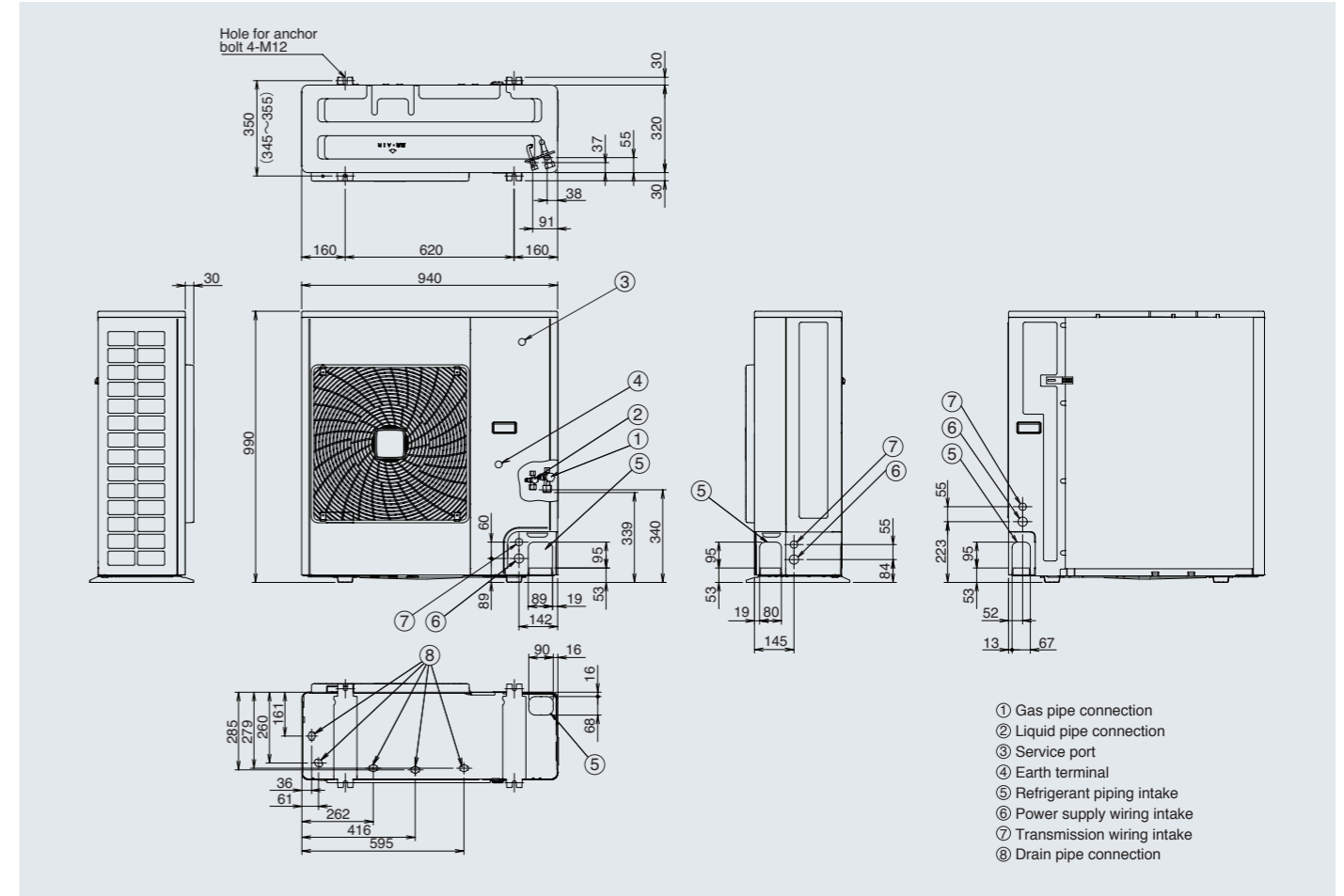

**OUTDOOR UNIT // RZF100CVM, RZF71/100CYM**

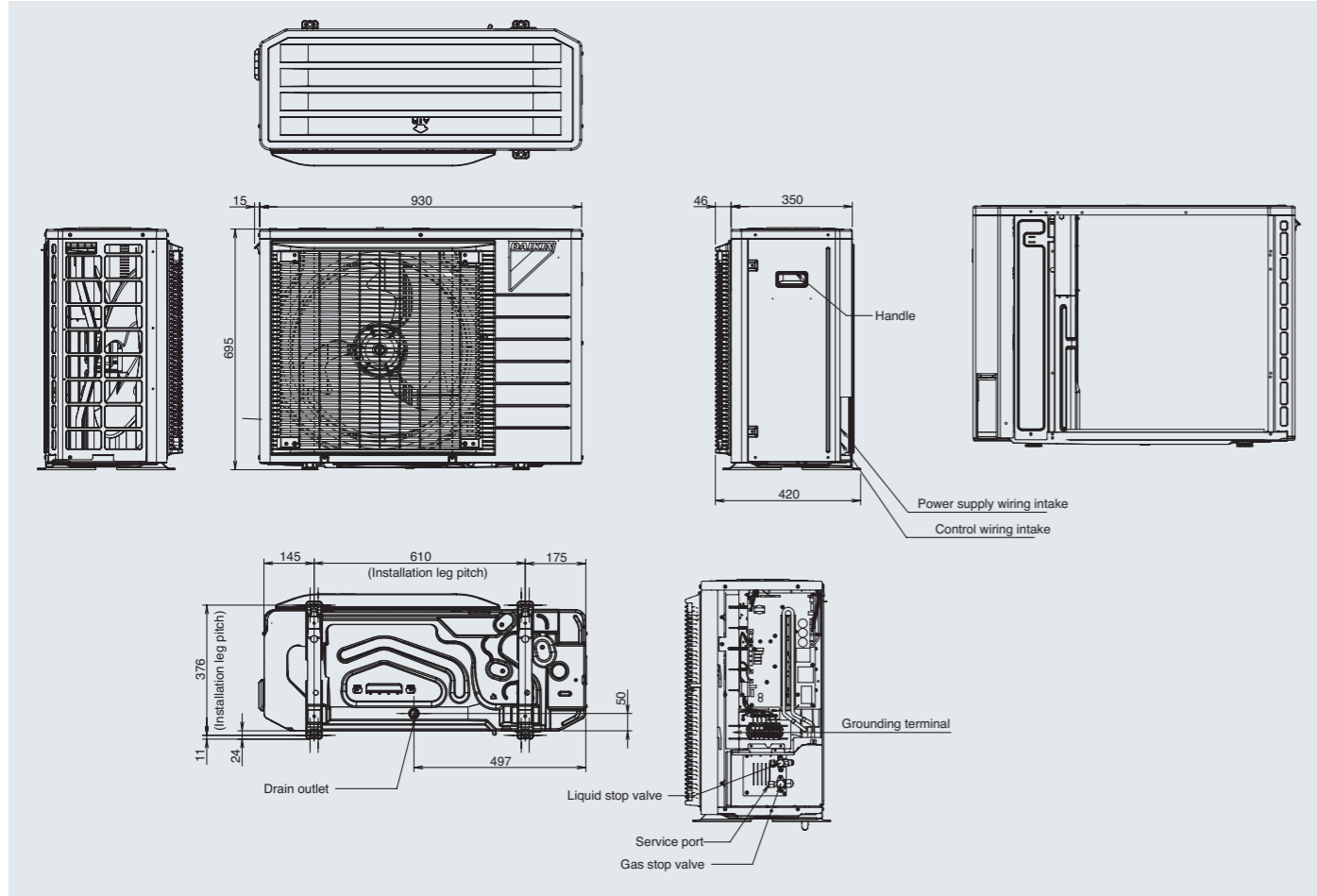

**OUTDOOR UNIT // RZA71/100BV2V**

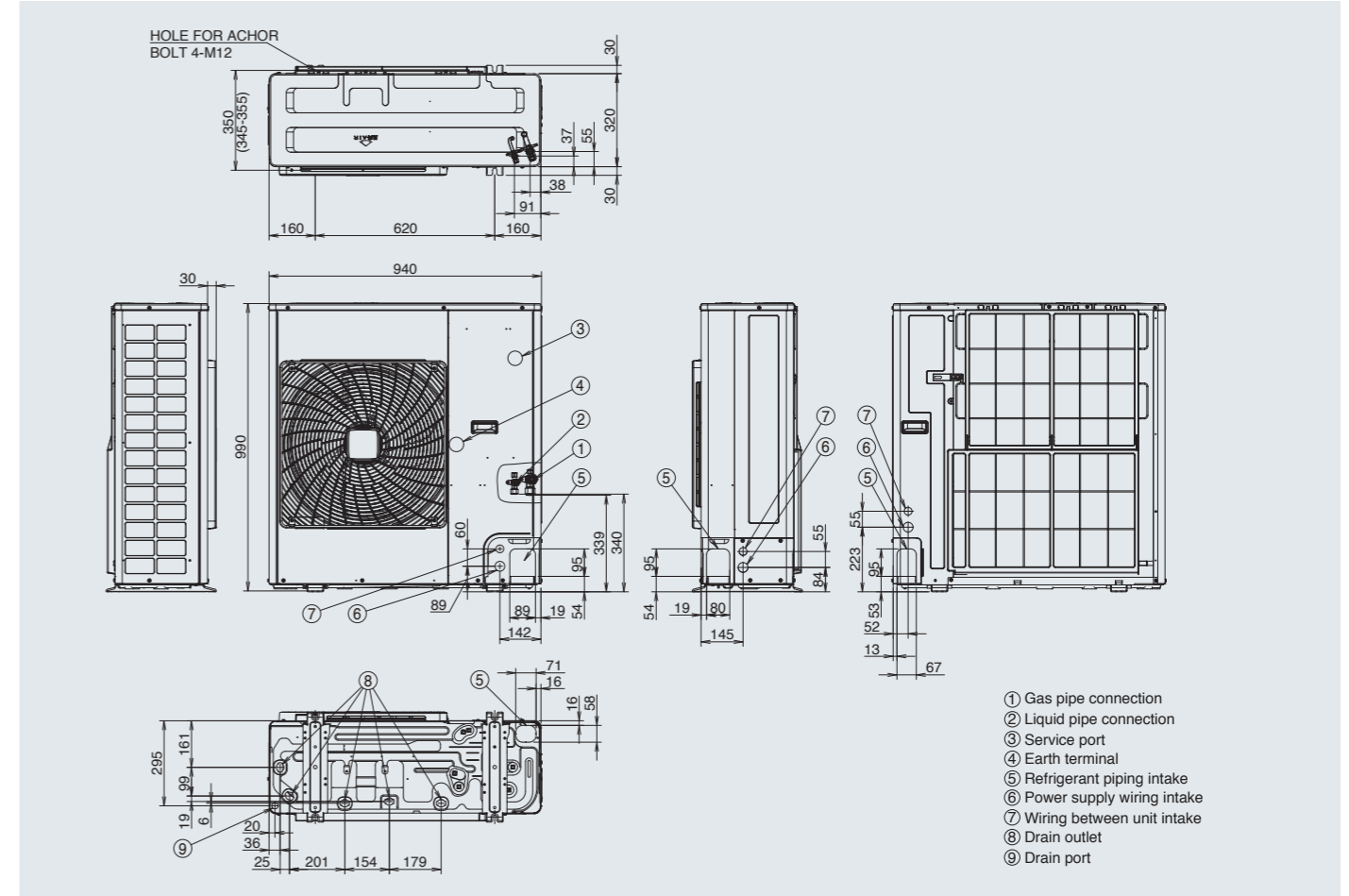

**REMOTE CONTROLLER**

《Wireless type》

Remote controller dimensions

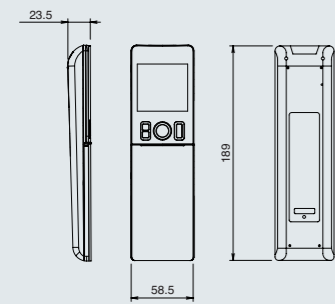

Remote controller dimensions

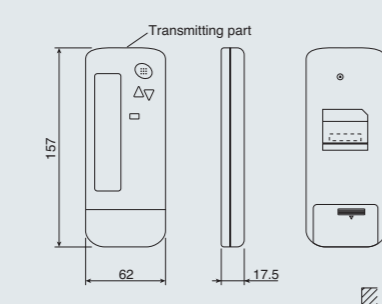

Remote controller holder installation procedure (Installation to wall surface)

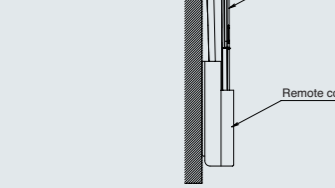

Remote controller holder installation procedure (Installation to wall surface)

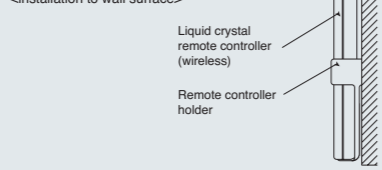

**CEILING MOUNTED CASSETTE TYPE <Round Flow>**

Receiver installation procedure

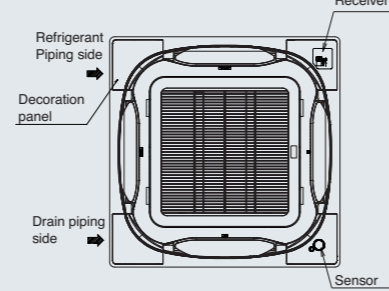

Receiver detail

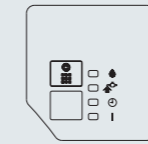

**COMPACT MULTI FLOW CEILING MOUNTED CASSETTE TYPE**

Receiver installation procedure

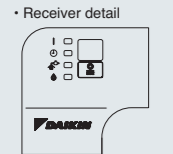
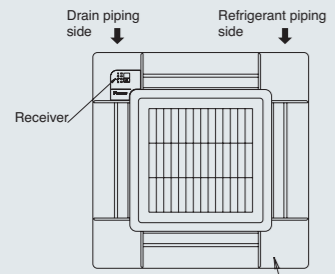

**CEILING MOUNTED BUILT-IN TYPE DUCT CONNECTION MIDDLE STATIC PRESSURE TYPE FLOOR STANDING TYPE**

Receiver detail

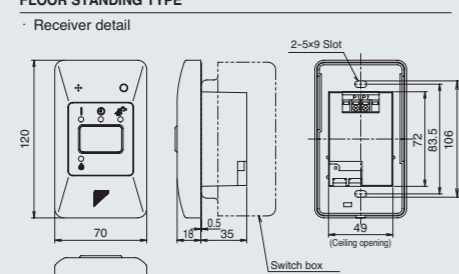

Receiver detail

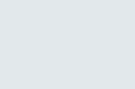

Service space for ceiling installation



**CEILING SUSPENDED TYPE**

Receiver installation procedure

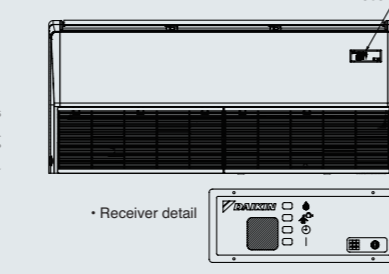

Receiver detail

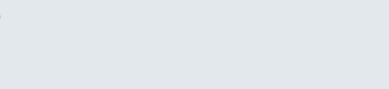

《Wired type》

**BRC1E63**

Remote controller dimensions

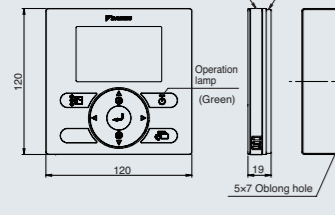

Installation method

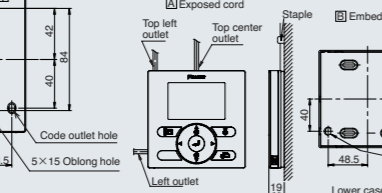

Embedded cord (use switch box)

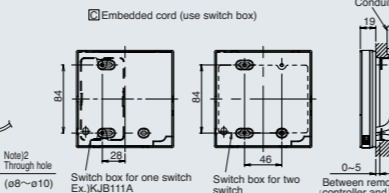

Note  
1. Remote controller cord and staple are not attached. They are field supplied parts.  
2. If the hole size is too large or the location is not proper, the hole may come out from the remote controller.

Specifications of cord

Type	Vinyl cord with sheath or cable (insulated thickness: 1mm or more)
Size	0.75~1.25 mm <sup>2</sup>
Total length	500 m

■ For RZF50-140CVM / CV2V, RZF71-140CYM, RZA71/100BV2V series

★1.RZF50/60/71/100CVM / CV2V, 71/100CYM ★ 2.RZF125/140CVM / CYM, RZA71/100BV2V series

**1 When there is an obstruction on the inlet side**

**1) When the overhead space is open**

1. For single unit installation

When there is an obstruction only on the inlet side

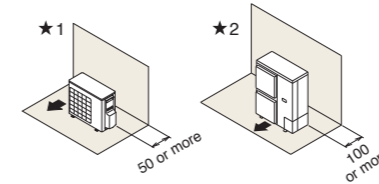

When there are obstructions on both sides

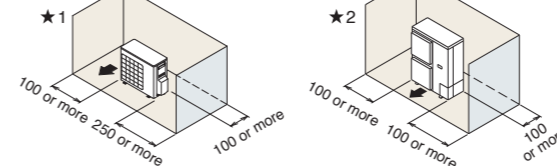

2. For multiple units installation (more than two units)

When there are obstructions on both sides

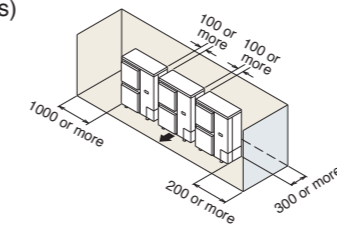

**2 When there is an obstruction on the outlet side**

**1) When the overhead space is open**

1. For single unit installation



2. For multiple units installation (more than two units)

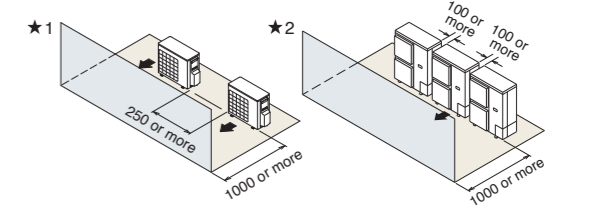

**2) When there is an obstruction in the overhead space**

1. For single unit installation

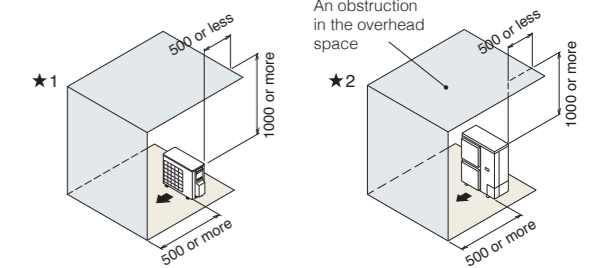

2. For multiple units installation (more than two units)

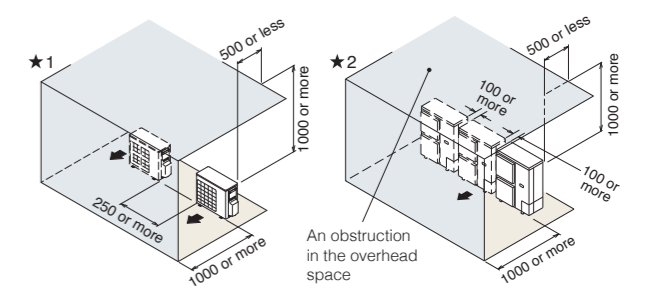

**2) When there is an obstruction in the overhead space**

1. For single unit installation

When there is an obstruction on the inlet side

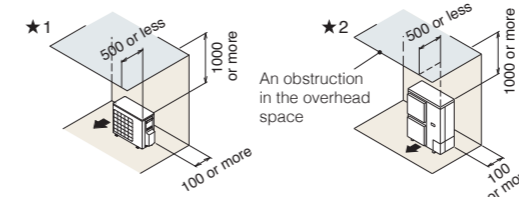

When there are obstructions on the inlet side and both lateral sides

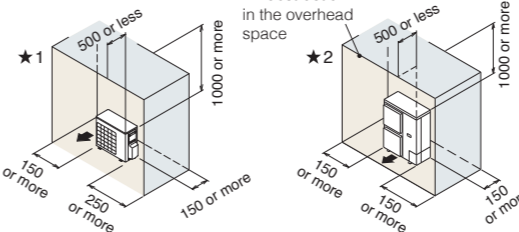

2. For series installation (more than two units)

When there are obstructions on the inlet side and both lateral sides

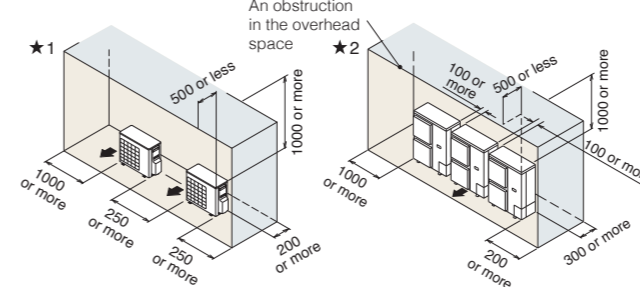

**3) When there are obstructions on both the inlet and outlet sides**

(When the obstruction on the outlet side is higher than the unit itself)

**1) When the overhead space is open**

(There is no limit to the height of the obstruction on the outlet side.)

1. For single unit installation

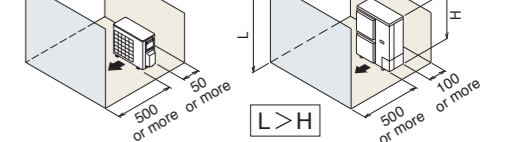

2. For series installation (more than two units)

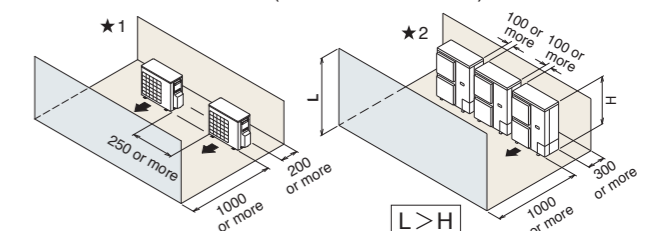

Note : As for other patterns of installation, please refer to Installation manual or Engineering Data Book.